

PUBLICATIONS OF  
THE UNIVERSITY OF EASTERN FINLAND

*Dissertations in Education,  
Humanities, and Theology*



UNIVERSITY OF  
EASTERN FINLAND

**SANNA VÄISÄNEN**

**STUDENT TEACHERS' STUDY WELL-BEING IN  
TEACHER EDUCATION**

*How is it constructed and regulated during studies?*



# STUDENT TEACHERS' STUDY WELL-BEING IN TEACHER EDUCATION

**HOW IS IT CONSTRUCTED AND REGULATED DURING STUDIES?**



*Sanna Väisänen*

**STUDENT TEACHERS' STUDY WELL-BEING  
IN TEACHER EDUCATION**

**HOW IS IT CONSTRUCTED AND REGULATED DURING STUDIES?**

Publications of the University of Eastern Finland  
Dissertations in Education, Humanities, and Theology  
No 142

University of Eastern Finland  
Joensuu  
2019

Grano Oy  
Jyväskylä, 2019  
Editor: Sirpa Kärkkäinen  
Sales: University of Eastern Finland Library  
ISBN: 978-952-61-3125-2 (print)  
ISBN: 978-952-61-3126-9 (PDF)  
ISSNL: 1798-5625  
ISSN: 1798-5625  
ISSN: 1798-5633 (PDF)

Väisänen, Sanna

Student teachers' study well-being in teacher education. How is it constructed and regulated during studies?

University of Eastern Finland, 2019, 80 pages

Publications of the University of Eastern Finland

Dissertations in Education, Humanities, and Theology; 142

ISBN: 978-952-61-3125-2 (print)

ISBN: 978-952-61-3126-9 (PDF)

ISSNL: 1798-5625

ISSN: 1798-5625

ISSN: 1798-5633 (PDF)

## ABSTRACT

This dissertation study explored student teachers' study well-being. More specifically, the focus was on investigating the construction of the student teachers' experienced study well-being and its regulation during teacher education studies. This dissertation is comprised of three sub-studies. Research data consisted of two data sets; qualitative interviews of the final-stage primary school and subject student teachers (N = 40) in a Finnish university as well as quantitative cross-sectional (N = 240) and longitudinal survey data (N = 270 T1) collected from the primary school student teachers at three Finnish universities. Thus, the study combined both qualitative and quantitative methods and further, drew on ideas of mixed methods research. Interview data were analysed by content analysis and survey data principally by structural equation modeling (SEM).

*Study I* examined the social support system provided by teacher education, especially the meaning of the social support to student teachers' experiences of their study well-being. Results showed that teacher education educed both empowering and burdening experiences, which included social support or lack of it. Formal and informal social support experienced during studies were divided into informational, emotional and instrumental types of support, of which informational and emotional support were most frequently reported. Experienced match between the type of support and its appropriateness enhanced students' empowerment. Contrarily, non-appropriate support and lack of support were sources of burdening during studies. In students' experiences, the significance of social support was recognised, however, initiatives of asking for or offering the support and reciprocal support were clearly less described.

*Study II* investigated first-year primary school student teachers' use of proactive strategies and the interrelation of those to different dimensions of study burnout. It was detected in the research that proactive strategies, i.e. self-regulation and co-regulation, adopted by student teachers regulated their risk of study burnout. Particularly, self- and co-regulation buffered exhaustion and feelings of inadequacy in studying. Feelings of inadequacy, in turn, were associated with student teachers' higher cynicism towards studies. In summary, proactive strategies enhanced student teachers' study well-being at the beginning of their studies.

*Study III* focused on analysing how student teachers' proactive strategies to regulate study well-being and the teacher education learning environment were interrelated to study burnout during bachelor-phase studies, i.e. during the first three years of studies. According to the central results of *study III* the use of self-regulative strategy

adopted by student teachers enhanced the use of co-regulative strategy, which in turn constructed the fit between a student teacher and the learning environment. Further, a positively experienced learning environment decreased the risk of study burnout. The risk of study burnout was buffered by exploitation of self-regulative strategies, also. Moreover, the results indicated that proactive strategies, experienced learning environment and study burnout were rather stable and could be predicted over time.

Early career teachers' and teachers' well-being has been studied widely, yet research on student teachers' study well-being and how it is constructed and regulated is scarcer. This dissertation study contributes to the literature on student teachers' study well-being by showing that student teachers' study well-being is constructed in relation to the learning environment formed in teacher education, as well as social support resources enabled by associated informal and formal interrelationships. Moreover, student teachers regulate proactively their own well-being, not only by themselves but also together with other people in the learning environment. Ability to support one's own study well-being, in turn, may promote student teachers' transition to work life, since the beginning phases of a teaching career may be challenging. The findings of this dissertation imply that learning both to understand and to actively formulate the dynamic interrelations of proactive self-regulative and co-regulative strategies and a supportive learning environment, in terms of enhancing study well-being, should be facilitated from the beginning of teacher studies.

**Key words:** *study well-being, study burnout, proactive self-regulative and co-regulative strategies, social support, learning environment, student teacher, teacher education*



Väisänen, Sanna

Opettajaksi opiskelevien opiskeluhyvinvointi opettajankoulutuksessa. Kuinka se rakentuu ja miten sitä säädellään opintojen aikana?

Itä-Suomen yliopisto, 2019, 80 sivua

Publications of the University of Eastern Finland

Dissertations in Education, Humanities, and Theology; 142

ISBN: 978-952-61-3125-2 (nid.)

ISBN: 978-952-61-3126-9 (PDF)

ISSNL: 1798-5625

ISSN: 1798-5625

ISSN: 1798-5633 (PDF)

## TIIVISTELMÄ

Tässä väitöskirjassa tutkittiin opettajaksi opiskelevien opiskeluhyvinvointia. Eryteisesti tarkasteltiin koetun opiskeluhyvinvoinnin rakentumista ja säätelyä opettajankoulutuksen opintojen aikana. Väitöskirja koostuu kolmesta osatutkimuksesta. Tutkimusaineisto muodostui kahdesta aineisto-osasta: yhden suomalaisen yliopiston loppuvaiheen luokan- ja aineenopettajaopiskelijoiden (N = 40) kvalitatiivisista haastatteluista sekä kolmen suomalaisen yliopiston luokanopettajaopiskelijoiden kvantitatiivisesta poikittaistutkimuksen (N = 240) ja pitkittäistutkimuksen kyselyaineistosta (N = 270 T1). Näin ollen tutkimuksessa yhdisteltiin laadullisia ja määrällisiä menetelmiä ja se perustui monimenetelmälliseen tutkimukseen. Haastatteluaineiston analysoinnissa käytettiin sisällönanalyysia ja kyselyaineiston analysoinnissa ensisijaisesti rakenneyhtälömallinnusta.

Ensimmäisessä osatutkimuksessa tarkasteltiin opettajankoulutuksen tarjoamaa sosiaalisen tuen järjestelmää, erityisesti sosiaalisen tuen merkitystä opiskelijoiden opiskeluhyvinvoinnin kokemiselle. Tulokset osoittivat, että opettajankoulutus sai esiin sekä voimaannuttavia että kuormittavia kokemuksia opettajaopiskelijoille, sosiaalisella tuella tai sen puutteella ollessa tässä kokemuksessa oma osuutensa. Opintojen aikana koettu formaali ja informaali sosiaalinen tuki oli jaoteltavissa informaationaalisena, emotionaalisen ja instrumentaalisen tuen muotoihin, joista informaationaalinen ja emotionaalinen tuki olivat useimmin mainittuja tuen muotoja. Koettu yhteensopivuus tuen muodon ja sen osuvuuden välillä edisti voimaantumista. Sitä vastoin osuuton tuki ja tuen puute kuormittivat opintojen aikana. Opiskelijoiden kokemuksissa sosiaalisen tuen merkitys hyvinvoinnin edistäjänä tunnistettiin, sitä vastoin tuen pyytämisen ja tarjoamisen aloitteita sekä tuen vastavuoroisuutta kuvattiin selkeästi vähemmän.

Toisessa osatutkimuksessa tutkittiin ensimmäisen vuoden luokanopettajaopiskelijoiden proaktiivisten strategioiden käytön yhteyttä opiskelu-uupumuksen eri ulottuvuuksiin. Tutkimuksessa havaittiin, että opettajaksi opiskelevien omaksumat proaktiiviset strategiat, itse- ja yhteissäätelystrategiat, säätelivät heidän opintoihinsa yhteydessä olevaa riskiä uupumukseen. Itse- ja yhteissäätelystrategiat puskuroivat erityisesti uupumusasteista väsymystä ja opintoihin liittyvää riittämättömyyden tunnetta. Riittämättömyyden tunne puolestaan oli yhteydessä opiskelijan korkeampaan kyynisyyteen opinnoissa. Kokoavasti voidaan todeta, että proaktiiviset strategiat edistivät opiskelijoiden hyvinvointia opintojen alussa.

Kolmannessa osatutkimuksessa keskityttiin analysoimaan sitä, kuinka opettajaksi opiskelevien opiskeluhyvinvointia säätelevät proaktiiviset strategiat ja opettajankoulutuksen oppimisympäristö olivat yhteydessä opiskelu-uupumukseen kandidaattiin eli kolmen ensimmäisen opintovuoden opintojen aikana. Kolmannen osatutkimuksen keskeisimpien tulosten mukaan opettajaksi opiskelevien omaksumien itsesääätelystrategioiden käyttö edisti myös yhteissääätelystrategioiden käyttöä, mikä puolestaan rakensu suhdetta opiskelijan ja oppimisympäristön välillä. Edelleen, myönteisenä koettu oppimisympäristö vähensi opintojen aikaista uupumusta. Lisäksi opintoihin liittyvää riskiä opiskelu-uupumukseen puskuroi itsesääätelystrategioiden hyödyntäminen. Rakenteet olivat ajassa pysyviä ja ennustettavissa.

Alkuvaiheen opettajien ja opettajien hyvinvointia on tutkittu laajalti, kuitenkin opettajaksi opiskelevien hyvinvointia sekä sen rakentumista ja säätelyä koskeva tutkimus on vähäisempää. Tämä väitöskirjatutkimus edistää opettajaksi opiskelevien hyvinvointia koskevaa tutkimusta osoittamalla, että opettajaksi opiskelevien opiskeluhyvinvointi rakentuu suhteessa opettajankoulutuksen muodostamaan oppimisympäristöön sekä oppimisympäristön informaaliin ja formaaliin vuorovaikutussuhteiden mahdollistamaan sosiaalisen tuen resurssiin. Lisäksi opettajaksi opiskelevat säätelevät proaktiivisesti omaa hyvinvointiaan paitsi itse myös yhdessä vertaisten kanssa. Kyky tukea omaa opiskeluhyvinvointia puolestaan voi edistää opettajaksi opiskelevien siirtymistä työelämään, sillä työelämän alkuvaihe voi olla haastava. Väitöskirjan tulosten perusteella voidaan esittää, että ymmärrystä proaktiivisten itse- ja yhteissääätelystrategioiden ja opiskeluhyvinvointia tukevan oppimisympäristön välisistä dynaamisista suhteista sekä niiden aktiivisen muodostamisen oppimista opiskeluhyvinvoinnin edistämiseksi tulisi tukea jo opettajaopintojen alusta lähtien.

***Avainsanat:** opiskeluhyvinvointi, opiskelu-uupumus, proaktiiviset itse- ja yhteissääätelystrategiat, sosiaalinen tuki, oppimisympäristö, opettajaopiskelija, opettajankoulutus*

# ACKNOWLEDGEMENTS

It has become time to pronounce thanks to those who have centrally contributed to the creation of my dissertation. After my graduation as a primary school teacher, I worked for six years as a teacher in different grades and schools. During that time, I had an opportunity to see the hecticness of teachers' work as well as the factors that challenge teachers' well-being at work. This theme of well-being began to interest me, but the actual topic of my dissertation became clear only after my discussion with my main supervisor, Professor Janne Pietarinen.

I am grateful for the opportunity that allowed me to do my dissertation as a part of research group. It has been a safe and encouraging learning environment to debate on my own thoughts, receive feedback, learn and succeed – and also fail sometimes. I wish to express my gratitude to my main supervisor, Professor Janne Pietarinen, for the numerous discussions on conducting research. You created enthusiasm and instilled belief in my abilities while discussing my research, and were always willing to share your broad expertise with me. I also want to thank my other three supervisors, Professor Kirsi Pyhältö, Professor Auli Toom and Research Director PhD Tiina Soini-Ikonen, for sharing your practical and theoretical expertise with me. You all have not only given me valuable, constructive feedback and encouragement throughout the whole process but also challenged me to think further and more deeply. I would also like to thank my peer doctoral students of our research group for the support and interesting discussions. Especially, I would like to thank Emmi Saariaho-Räsänen whose support and encouragement have been so meaningful both in good and challenging times. I still warmly remember the first research group meeting at Helsinki when you offered to meet me at bus station so that we could go to the university together. Thanks to you, I immediately felt welcomed as a member of our research group. Furthermore, I would like to thank all the student teachers without whom this dissertation study would not have been possible. They have given me their time year after year and answered to my surveys and one interview.

I would like to thank the official reviewers of my dissertation, University Lecturer PhD Heta Tuominen and Senior Lecturer, Research Director PhD Vesa Korhonen for immersing yourselves into my dissertation and giving constructive and encouraging comments, which have allowed me to develop my dissertation even further. I also want to express my gratitude to Professor Hannele Niemi for being my opponent at the public defence of my dissertation.

I have many colleagues who have shared this journey with me. I warmly thank University Lecturer, Research Director PhD Laura Hirsto, with whom I have taken my first steps in teaching in higher education institutions and learnt many aspects of the various phases of doing research. You have supported me and been there for me at all times. Most of all, you have been my friend. I also want to thank Professors Anna-Liisa Elorinne and Kati Mäkitalo for our walks and trips on which I have been able to talk to you about conducting research and about the academic world in general. I am grateful to University Lecturer PhD Sirpa Kärkkäinen for all your encouragement during this process. I am really looking forward to our trip to national park now that I have finished my dissertation.

I also want to thank – from the bottom of my heart – my fellow doctoral students, some of which have already received their doctorate. Without you I may not have

been able to finish this process. At first, I would like to thank University Lecturer PhD Serja Turunen, who encouraged me to contact my supervisor and gave me the first push to the path of research. I would also like to express my gratitude to PhD Olli Rissanen and the members of "downstairs Mensa" Saara Nissinen, Hanna Nygren and Wille Hartonen. It has been so great being surrounded by peers with whom you can share your joys and even anxieties regarding your research and who understand the thoughts that arise from doing your dissertation. You all have made this journey of mine very memorable!

I am also grateful for being able to work as a full-time researcher, and for this reason I would like to thank our research group project, supported by Academy of Finland, for funding the first steps of my doctoral student journey. Especially, I would like to thank for the financial support of Doctoral Programme in Educational Sciences, Philosophical Faculty for giving me a four-year position of an early-stage researcher. Also, the Finnish Cultural Foundation, South Savo Regional Fund has made it possible for me to finish this work as a full-time researcher by granting my scholarship.

I wish to thank all my friends who have contributed on this work. Special thanks to my dear friend Tiia, who has always been there for me and who has had enough strength to support my journey of making this dissertation. You have been happy about my success and scholarships and supported me in times when my goal has not been clear. Our friendship means a lot to me! Most of all I would like to thank my family and relatives for all the cheers and encouragement during this process. I am grateful for my parents Pertti and Tuula, and my siblings Laura and Joonas for all the support I have received. My dad has been an excellent expert, also. Finally, this dissertation is dedicated to my late grandmother, who supported me throughout all of my studies and also the early stages of this process. You always listened me and wanted to know more about my research.

In Savonlinna, May 2019  
Sanna Väisänen

# LIST OF ORIGINAL PUBLICATIONS

This dissertation is based on three original publications, which are referred to in the text by Roman numerals I–III.

- I Väisänen, S., Pietarinen, J., Pyhältö, K., Toom, A., & Soini, T. (2016). Social support as a contributor to student teachers' experienced well-being. *Research Papers in Education*, 32(1), 41–55. doi: 10.1080/02671522.2015.1129643
- II Väisänen, S., Pietarinen, J., Pyhältö, K., Toom, A., & Soini, T. (2018). Student teachers' proactive strategies for avoiding study-related burnout during teacher education. *European Journal of Teacher Education*, 41(3), 301–317 doi: 10.1080/02619768.2018.1448777
- III Väisänen, S., Pietarinen, J., Pyhältö, K., Toom, A., & Soini, T. (2018). Student teachers' proactive strategies and experienced learning environment for reducing study-related burnout. *Journal of Education and Learning*, 7(1), 208–222. doi:10.5539/jel.v7n1p208

The original articles are reprinted with the permission of the copyright holders.

This research is carried out as a part of the Learning and Development in School (OPPI) research group. The first author of the articles, Sanna Väisänen, has been a corresponding author in all three articles included in this dissertation. She designed the study, analysed the data and wrote articles. In addition, she has taken part in data collection in *studies II* and *III*. Supervisors Janne Pietarinen, Kirsi Pyhältö, Auli Toom and Tiina Soini-Ikonen designed data collection as well as supervised analyses and took part in editing article manuscripts during the research project.

The studies were funded by the Academy of Finland (research projects: 1259489 and 295022), Philosophical Faculty of the University of Eastern Finland and The Finnish Cultural Foundation (South Savo Regional Fund).



# CONTENTS

|   |           |
|---|-----------|
| <b>ABSTRACT</b> .....   | <b>5</b>  |
| <b>TIIVISTELMÄ</b> .....  | <b>7</b>  |
| <b>ACKNOWLEDGEMENTS</b> .....   | <b>9</b>  |
| <b>LIST OF ORIGINAL PUBLICATIONS</b> .....  | <b>11</b> |
| <b>1 INTRODUCTION</b> .....   | <b>15</b> |
| 1.1 Student teachers' well-being in the teacher education learning<br>environment .....   | 16        |
| 1.1.1 Student teachers' study well-being .....  | 16        |
| 1.1.2 Burnout as an indicator of study well-being .....   | 16        |
| 1.1.3 Factors regulating study well-being in teacher education .....  | 18        |
| 1.2 Proactive strategies to regulate study well-being in the teacher education<br>learning environment .....                                    | 21        |
| 1.2.1 Social support resource in the learning environment.....  | 21        |
| 1.2.2 Proactive strategies to regulate the risk of burnout .....  | 23        |
| 1.3 Summary of the theoretical framework .....  | 26        |
| <b>2 THE AIM OF THE STUDY</b> .....   | <b>29</b> |
| <b>3 METHODS AND PROCEDURES</b> .....   | <b>31</b> |
| 3.1 Teacher education in Finland .....  | 31        |
| 3.2 Participants .....  | 33        |
| 3.3 Materials .....   | 34        |
| 3.3.1 Interview data .....  | 34        |
| 3.3.2 Survey data.....  | 35        |
| 3.4 Analyses.....   | 36        |
| 3.4.1 Interview study I.....  | 36        |
| 3.4.2 Survey studies II and III .....   | 37        |
| 3.5 Summary of the methods.....   | 39        |
| <b>4 RESULTS</b> .....  | <b>40</b> |
| 4.1 Social support as a contributor to student teachers' experienced<br>well-being ( <i>Study I</i> ) .....                                     | 40        |
| 4.2 Student teachers' proactive strategies for avoiding study-related burnout<br>during teacher education ( <i>Study II</i> ).....              | 44        |
| 4.3 Student teachers' proactive strategies and experienced learning<br>environment for reducing study-related burnout ( <i>Study III</i> )..... | 46        |
| <b>5 DISCUSSION</b> .....   | <b>49</b> |
| 5.1 Methodological reflections.....   | 49        |
| 5.1.1 General methodological reflections.....   | 49        |
| 5.1.2 Methodological reflections of interview study.....  | 50        |
| 5.1.3 Methodological reflections of survey studies .....  | 51        |
| 5.1.4 Research ethics .....   | 53        |
| 5.2 Theoretical reflections and the synthesis of the findings.....  | 54        |
| 5.3 Educational implications.....   | 58        |
| 5.4 Future research.....  | 61        |

|                               |           |
|-------------------------------|-----------|
| <b>REFERENCES.....</b>        | <b>64</b> |
| <b>APPENDICES.....</b>        | <b>75</b> |
| <b>ORIGINAL ARTICLES.....</b> | <b>81</b> |

**LIST OF TABLES**

|          |   |    |
|----------|---|----|
| Table 1. | Summary of the overall aim, research questions and the sub-study research questions and hypotheses for <i>studies I, II and III</i> ..... | 30 |
| Table 2. | Response rates, gender and age at <i>study I, study II and study III</i> (time 1, 2, and 3).....  | 34 |
| Table 3. | Summary of the methodological choices in the three sub-studies.....   | 39 |
| Table 4. | Student teachers' sense of informational support.....   | 41 |
| Table 5. | Student teachers' sense of emotional support.....   | 43 |
| Table 6. | Student teachers' sense of instrumental support.....  | 44 |

**LIST OF FIGURES**

|           |   |    |
|-----------|---|----|
| Figure 1. | Social support system provided by teacher education (adapted from Pyhältö, 2018).....   | 21 |
| Figure 2. | A visualisation of the key concepts of the study.....   | 28 |
| Figure 3. | A visualisation of the analysis process in study I.....   | 37 |
| Figure 4. | Model of student teachers' proactive strategies to regulate study-related burnout: $\chi^2 (81) = 163.35, p < .001$ ; RMSEA = .07 (90% C.I. .05/.08); CFI/TLI = .94/.92; SRMR = .09.....  | 46 |
| Figure 5. | Standardised model: $\chi^2 (42) = 54.916^*, p = .09$ ; RMSEA = .03 (90% C.I. = .00–.06); CFI/TLI = .99/.98; SRMR = .07. * $\chi^2/df$ ratio = 1.31. All parameters were significant at <i>p</i> level <.05. Note: One [autocorrelative] residual covariance of the observed factor indicators was added..... | 47 |



# 1 INTRODUCTION

Student teachers recognise burnout as a serious professional risk; they do not, however, expect themselves to experience it (Hong, 2010). Beginning teachers are typically satisfied with and enthusiastic about their work (Goddard & Goddard, 2006; Stockard & Lehman, 2004). They also find teaching to be demanding (Hagger, Mutton, & Burn, 2011), and they suffer from stress (Hillel Lavian, 2012; Skaalvik & Skaalvik, 2015; Soini, Pyhältö, & Pietarinen, 2010; Tynjälä & Heikkinen, 2011), which may expose them to burnout at the beginning of their career. On the other hand, students who do not suffer from such stages, including student teachers, are more flexible and efficient in solving problems faced during their studies (Hascher, Cocard, & Moser, 2004; Salami, 2010). They are also shown to be committed to academic goals and have a control of their own studies (Salami, 2010). The ability to study may anticipate ability to work, and further, how students learn to deal with stressors may transfer into the working life (Säntti, 1999). Further, beginning teachers with a good overall sense of well-being (including sense of connectedness, competence and professional development) are able to think positively about demands of the job, set realistic coping strategies for challenging and burdening times and have confidence to ask for help from peers (McCallum & Price, 2010). Yet, even though the literature on teachers' occupational well-being is quite extensive, there is a need to gain a better understanding of student teachers' study well-being, especially how student teachers construct and regulate their well-being or experiences of burnout during teacher studies in the specific teacher education learning environment.

There is evidence that strategies student teachers use to handle stressors during studies are associated with their study well-being (Carnicer & Calderón, 2014; Chao, 2011; Gustems-Carnicer & Calderón, 2013). Yet, some of the student teachers have been shown to display unhealthy coping behaviours and experience exhaustion (Reichl, Wach, Spinath, Brünken, & Karbach, 2014). This implies that student teachers need to learn functional strategies to build and sustain their well-being such as seeking, using and providing social support (Hoy & Spero, 2005; Schliechte, Yssel, & Merbler, 2005) as well as how to plan and organise their studies (Aspinwall & Taylor, 1997; McCallum & Price, 2010; Straud, McNaughton, Cassill, & Fuhrman, 2015) not only during and for the studies, but also in their future work.

A better understanding of the construction of student teachers' study well-being enables the building of the kind of learning environment that supports both study well-being as well as sufficient strategies for building it. Hence, this study aims to contribute to the literature on student teacher well-being by exploring how social support system enabled during teacher education promotes experienced study well-being, the association between proactive self-regulative and co-regulative strategy use, learning environment in teacher education and a risk of study burnout experienced by student teachers.

## 1.1 STUDENT TEACHERS' WELL-BEING IN THE TEACHER EDUCATION LEARNING ENVIRONMENT

### 1.1.1 Student teachers' study well-being

Student teachers' feelings and thoughts about their lives (including teacher studies) have a significance in understanding well-being (see Diener, Oishi, & Lucas, 2003). This study draws on the literature on psychological and subjective well-being to explore student teachers' study well-being. Psychological and subjective well-being are related, yet separate, dimensions (Keyes, Shmotkin, & Ryff, 2002; Linley, Maltby, Wood, Osborne, & Hurling, 2009) that may operate together and overlap each other (Kashdan, Biswas-Diener, & King, 2008). Hence, in this study the expression *student teachers' study well-being* is used to refer to psychological well-being and student teachers' subjective evaluations of it concerning their studies in the teacher education learning environment that supports or challenges study well-being in a dynamic interplay between a student teacher and the teacher education learning environment.

The *psychological* aspects of study well-being are characterised by feeling good and functioning effectively (Huppert, 2009), this is, the presence of relatedness and competence (Samman, 2007). Positive relationships with other people, as a part of psychological well-being, refers to trusting relationships, and that one is capable of empathy, sees the reciprocity of relationships (Ryff, 1995) and is supported by others (Kern, Waters, Adler, & White, 2015). Additionally, psychological well-being is embodied by environmental mastery (i.e. sense of managing one's own environment and effective use of opportunities) and both personal (i.e. sense of continued development) (Ryff, 1995; Ryff & Keyes, 1995) and psychological growth (Deci & Ryan, 2000), which refers to in this study developing to be a teacher. Also, individuals' sense of meaning is included (Samman, 2007). *Subjective well-being*, on the other hand, comprises subjective evaluations of aspects of one's life (Diener, 2006; Diener et al., 2003; Diener, Oishi, & Lucas, 2011), such as being a student teacher. These evaluations can be positive or negative and consider, for example, satisfaction with relationships, meaning (Diener & Ryan, 2009), feeling of mastery or reaching set goals (Diener, Sapyta, & Suh, 1998) in teacher studies. Subjective well-being includes experiences of high levels of positive and pleasant emotions and low levels of negative emotions (Diener et al., 2011) and the balance between these emotions (Keyes et al., 2002).

### 1.1.2 Burnout as an indicator of study well-being

Students may suffer from lowered study well-being (Bewic, Koutsopoulou, Miles, Slaa, & Barkham, 2010; Salmela-Aro & Read, 2017; Tuominen-Soini & Salmela-Aro, 2014), for instance, experience psychological distress during their university studies (Bewic et al., 2010; Caires, Almeida, & Vieira, 2012). It has been proposed, that students may even though distress to be as a part of being a student (Stallman, 2010). At its worst, prolonged stress caused by studies may result in study burnout (e.g., see Freudenberger, 1974; Kokkinos, 2007; Maslach, 2003; Maslach, Schaufeli, & Leiter, 2001; Salmela-Aro, 2009). Burnout has three distinctive symptoms, including exhaustion, cynicism, and inadequacy (Bresó, Salanova, & Schaufeli, 2007; Maslach et al., 2001; Moneta, 2011; Pietarinen, Pyhältö, Soini, & Salmela-Aro, 2013a; Pyhältö, Pietarinen, & Salmela-Aro,

2011; Schaufeli & Salanova, 2007; see also Bresó et al., 2007; Salmela-Aro, 2009; Salmela-Aro & Kunttu, 2010; Schaufeli & Salanova, 2007). *Exhaustion* (Leiter & Maslach, 2016; Maslach, 2003; Maslach & Goldberg, 1998; Maslach & Jackson, 1981; Maslach et al., 2001) refers to feelings of fatigue (Bresó et al., 2007; Schaufeli, Martínéz, Pinto, Salanova, & Bakker, 2002) or being exhausted because of study demands (Bresó et al., 2007; Salmela-Aro & Kunttu, 2010; Schaufeli et al., 2002). *Cynicism* embodies a negative or distant attitude towards work, study and other people (Bresó et al., 2007; Maslach, 2003; Maslach et al., 2001; Schaufeli et al., 2002) and a student may have lack of experiencing reasonableness in relation to their studies (Salmela-Aro, 2009). *Inadequacy* consists of feelings of incompetence, insufficiency and lowered sense of self-efficacy, i.e. inefficacy (Bresó et al., 2007; Maslach & Goldenberg, 1998; Schaufeli et al., 2002) and a reduced sense of accomplishment (Leiter & Maslach, 2016; Maslach et al., 2001). Students may also feel incompetent as a student (Bresó et al., 2007; Schaufeli et al., 2002) and that his or her study-related self-esteem has lowered (Salmela-Aro, 2009).

There is partly contradictory evidence on the development of burnout symptoms, especially in terms of inadequacy, despite the fact that the interrelation between the exhaustion and cynicism has been verified across multiple settings (Maslach, 2003; Maslach et al., 2001). Inadequacy is proposed to result both from exhaustion and cynicism, or it can also develop independently (Leiter, 1993; Maslach, 2003; Maslach & Jackson, 1981; Maslach & Leiter, 2008; Maslach et al., 2001). For example, exhaustion is found to predict cynicism that further contributes to inefficacy (Moneta, 2011). On the other hand, during the period of peak demand, employees may become seriously exhausted, but their cynicism remains low because they can address the demands through effective coping (Maslach & Leiter, 2008). However, it has been suggested that teachers' sense of insufficiency due to, for example, problematic encounters with pupils and a lack of skills to handle these burdening situations, may result in cynicism as a distancing mechanism (Pillay, Goddard, & Wilss, 2005).

The beginning of the teacher career is shown to be especially challenging (Goddard & Goddard, 2006; Goddard, O'Brien, & Goddard, 2006; McCallum & Price, 2010; Tynjälä & Heikkinen, 2011). Still, the majority of beginning teachers only experience low levels of burnout, which refers to good coping with the transition from teacher education to the teaching profession (Hultell, Melin, & Gustavsson, 2013). Yet, beginning teachers have been found to have increased risk of burnout compared to their more experienced colleagues (Brewer & Shapard, 2004; Gavish & Friedman, 2010; Goddard & Goddard, 2006). Beginning teachers also think that teaching predisposes to developing burnout (Hong, 2012). Teachers who start to develop burnout symptoms only a few months after entering a teaching career, may have started to experience burnout already during their studies in teacher education (Gavish & Friedman, 2010; Goddard et al., 2006). There is evidence that already student teachers suffer from burnout symptoms, particularly exhaustion (Chan, 2003; Fives, Hamman, & Olivarez, 2007). Good educational success and health is shown to predict lower initial levels of burnout, whereas strain and poor health during studies is linked to higher initial burnout levels among beginning teachers (Hultell et al., 2013). They have also been shown to suffer low levels of cynicism, whereas their sense of inadequacy is reported to be relatively high (Gavish & Friedman, 2010), which indicates that teaching creates feelings of professional incompetence and failure for beginning teachers (Gavish & Friedman, 2010; Tynjälä & Heikkinen, 2011). Yet, suffering from inefficacy only, that seems to be a typical experience for employees, is less negative than suffering from exhaustion, cynicism or overall burnout (Leiter & Maslach, 2016).

The risk of developing burnout is proposed to be cumulative, i.e. prior burnout experiences predict such experiences in the future (Maslach et al., 2001). Further, the majority of variable-based longitudinal studies show at least moderate levels of consistency in experienced burnout (Salmela-Aro, Savolainen, & Holopainen, 2009; see also Maslach & Leiter, 2008; Taris, Le Blanc, Schaufeli, & Schreurs, 2005), beginning teachers included (Gavish & Friedman, 2010). On the other hand, results of the longitudinal study with a person-centred approach have detected the occurrence of both increases and decreases in beginning teacher's burnout levels (Hultell et al., 2013; see also Leiter & Maslach, 2016). Students' experiences of inadequacy and cynicism are shown to increase gradually during study years also (Salmela-Aro & Read, 2017). It has been proposed that changes in exhaustion and cynicism profile of burnout may occur in both directions, positive or negative, resulting from match or mismatch between the individual and his or her work resources (Leiter & Maslach, 2016). Accordingly, exploring student teachers' teacher education learning environment is significant for understanding both student teachers' and teachers' well-being.

### **1.1.3 Factors regulating study well-being in teacher education**

Stress results from a challenging relationship between the individual and his or her environment (Folkman, 1984; Kokkinos, 2007), such as a challenging encounter between a student teacher and pupil during teaching practice or expectations concerning performance in studies. Further, this relationship is dynamic and changing, acting in both directions (Folkman, 1984). For example, an imbalance between high demands and low resources for students during their studies (Salmela-Aro, 2009; Salmela-Aro & Read, 2017), or teachers at work, may contribute to experiences of burnout (Hakonen, Bakker, & Schaufeli, 2006; Maslach, 2003; Peeters & Rutte, 2005). Alternatively, in school environments where resources and work demands are balanced, less stress arises (Sharplin, O'Neill, & Chapman, 2010). For example, cynicism is associated with environment in presence of poor quality of social relationships and lack of resources (Leiter & Maslach, 2016). Also, imbalance between effort put into work and reward received may induce burnout (Pillay et al., 2005; Unterbrink et al., 2007). Learning environment has been shown to have a significance to student teachers' study well-being (Price & McCallum, 2015). Furthermore, the study well-being is considered not only as an individual experience but also dynamics of the relationship between the student teacher and the teacher education learning environment, i.e. the fit between them (a match or a mismatch) (see Maslach, 2003; Maslach & Leiter, 2008; Maslach et al., 2001). For example, a good working environment fit reduces risk of burnout (Gavish & Friedman, 2010; Lam & Yan, 2011; Pyhältö et al., 2011). In this study, learning environment and the perceived fit between student teachers and their learning environment are considered through their social dimensions, especially in terms of received and provided social support, perceived equality and climate in teacher education and received recognition from teacher educators. Accordingly, the learning environment may support or challenge student teacher's study well-being (e.g., see Leiter & Maslach, 2016; Salmela-Aro, 2009).

Student teachers may face several stressors or demands that challenge their study well-being. For example, the teaching practice period is seen as a stressful and demanding phase of teacher studies (Caires et al., 2012; Chaplain, 2008; Klassen & Durksen, 2014), that may challenge student teachers' study well-being. Student teachers

are found to face similar stressors that are present during the actual teacher career, such as heavy workload, time management challenges and pressure as well as pupil misbehaviour (Chaplain, 2008; Geving, 2007; Klassen & Durksen, 2014; Knight, Balatti, Haase, & Henderson, 2010; Paquette & Rieg, 2016). They may also identify other stressors related to their professional development during teacher education, such as a teacher educator's expectations (Klassen & Durksen, 2014), concerns about their own competences (Knight et al., 2010; Zhang, Gan, & Cham, 2007) and performance as teachers (Chaplain, 2008; Paquette & Rieg, 2016). In addition, study-related stressors entail concerns about one's own academic ability (Zhang et al., 2007) and lack of confidence to reach the academic goals students have set for their own studies (Pierceall & Keim, 2007).

Even exhaustion may materialise while a student has, for example, worked for long time to reach the goals without necessary requirement (Salmela-Aro, 2009). It has been proposed that dedicated and committed people are prone to burnout as they work too much and intensively (Freudenberger, 1974), for example, putting a lot of effort into teaching and preparation to it may cause experience of high time pressure, which is related to exhaustion (Skaalvik & Skaalvik, 2010, 2017). Students performing below their own academic expectations may contribute to experienced exhaustion (Jacobs & Dodd, 2003), as well as those with high expectations since they may work too much and therefore suffer from burnout, also (Maslach et al., 2001). Yet, set high standards do not necessarily result in burnout when goals are realistic and achievable or when a student is capable to set standards again to a proper level (Zhang et al., 2007). Furthermore, students who perform academically well have less feelings of being exhausted and cynical, and further, cynicism is the least suffered by the most study-dedicated students (Schaufeli et al., 2002).

Distressful events in studies may result in student teachers' experiences of inadequacy (Lindqvist, Weurlander, Wernerson, & Thornberg, 2017). These experiences may result in if students perceive a gap between the level of their competence and academic demands too wide (Heikkilä, Lonka, Nieminen, & Niemivirta, 2012) or overwhelming problems faced in teacher–student relationships (see Pyhältö et al., 2011). However, it has been proposed that while student teachers' abilities to teach increase number of stressors emerging in a learning environment due to the inadequacy of teaching decrease (Fives et al., 2007). Even though feelings of uncertainty are common only few student teachers question their choice of teaching career (Timošćuk & Ugaste, 2010). On the other hand, it has been shown that beginning teachers with the high sense of well-being possess personal and professional protective qualities that enhance their competences, for example social competence and problem-solving strategies (McCallum & Price, 2010). High burnout is associated with perception of low competence (Pillay et al., 2005).

Environmental conditions may allow or hinder satisfaction in competence and relatedness, and further have an impact on individuals' mental health (Deci & Ryan, 2000). Individuals are the most fully functioning in those environments where they are able to experience these (Ryan & Deci, 2011), whereas absence of these in the environment may contribute to both alienation and lower well-being (Ryan & Deci, 2000) and even arouse burnout (Maslach et al., 2001). Feeling connected into school community enhances teachers' well-being (McCallum & Price, 2010). For example, teachers' well-being is enhanced by positive relationships with pupils (Roffey, 2012; see also Heikonen, Pietarinen, Pyhältö, Toom, & Soini, 2017) and relatedness with pupils is diminishing a risk of emotional exhaustion and supports teachers' enjoyment to teach (Klassen, Perry, &

Frenzel, 2012). However, for student teachers, connectedness to a teacher community during teaching practice is reported to lack (Timošćuk & Ugaste, 2010).

Student teachers' learning and study well-being is embedded in the social interactions in their learning environment including peer students and teacher educators. It has been suggested that student teachers' learning depends on the socio-emotional atmosphere during their teaching practice supported by supervisor teacher (Hascher et al., 2004; see also Anttila, Pyh lt , Soini, & Pietarinen, 2016). Yet, for student teachers, supportive atmosphere during teaching practice is reported to lack (Timošćuk & Ugaste, 2010). Supportive and good atmosphere is linked to well-being also at the beginning of teaching career (Gavish & Friedman, 2010). Yet, some teachers are concerned of their possibilities to share new ideas with their peers, which may be due to competitive atmosphere (Pashardis, 2000) and further, a highly competitive and comparative learning environment evidently increase negative outcomes among beginning teachers (Devos, Dupriez, & Paquay, 2012; Pashardis, 2000).

Beginning teachers are not satisfied with their professional recognition and appreciation by the teacher community (Gavish & Friedman, 2010). Collegial valuing of each other's is shown to be a negative predictor of emotional exhaustion (Dorman, 2003). A lack of recognition and appreciation reduce beginning teachers' sense of competence, and increase their feelings of failure, and further increase the risk of developing burnout (Gavish & Friedman, 2010). Previous research has also detected, that perceived fairness, an expression of respect, is significant structure between individual and environment, while disrespect may build exhaustion (Maslach et al., 2001) or even result in cynicism (Maslach & Leiter, 2008; Maslach et al., 2001). However, even if student teachers expect to have respect from supervisor teacher (Timošćuk & Ugaste, 2012), mutual respect from them during teaching practice is reported to lack (Timošćuk & Ugaste, 2010). Accordingly, it can be argued that being recognised and treated equally by the teacher educators may reduce student teachers' burdening (see also Maslach & Leiter, 2008; Maslach et al., 2001).

Teacher studies evoke both positive (e.g., enthusiasm, belonging) and negative (e.g., anxiety and inadequacy) emotions (Anttila et al., 2016), that may support or challenge well-being. Further, these academic emotions are resulted by complex dynamic between student teachers and their learning environment (Anttila et al., 2016). Even if some negative emotions belong to life, frequent and prolonged negative emotions can disturb effective functioning (Diener, 2006). Conversely, positive emotions during teaching practice are shown to support learning and professional development as a teacher (Hascher et al., 2004; Timošćuk & Ugaste, 2012). These positive emotions may evoke with encounters with pupils, for example pupils' friendly attitude, seeing student teachers as qualified teachers (Timošćuk & Ugaste, 2010), gaining respect from pupils (Timošćuk & Ugaste, 2012) or confidence to ability to engage pupils (Fives et al., 2007) that may support student teacher's study well-being. On the other hand, negative reactions to experiences on events include anxiety, worry, stress and frustration (Diener, 2006). For example, it has been shown that students, including student teachers, feel anxiety during their studies (Cooke, Bewick, Barkham, Bradley, & Audin, 2006; Timošćuk & Ugaste, 2012) and further, it has been proposed that student teachers who experience a lot of career anxiety also question their competence to teach (Daniels, Clifton, Perry, Mandzuk, & Hall, 2006), i.e. may have senses of inadequacy as a teacher. Student teachers typically report fear of failure during teaching practice and that negative emotions for student teachers may evoke for example sense of failure due to negative feedback from supervisor (Timošćuk & Ugaste, 2010). However, it has been shown that during

teaching practice, student teachers' level of competence increases, presumably because of increased experiences of being a teacher (Evelein, Korthagen, & Brekelmans, 2008). Further, being able to manage negative emotions (that may arise in teacher studies, also) is substantial for well-being in a longer time period (Huppert, 2009).

## 1.2 PROACTIVE STRATEGIES TO REGULATE STUDY WELL-BEING IN THE TEACHER EDUCATION LEARNING ENVIRONMENT

### 1.2.1 Social support resource in the learning environment

Teacher education provides an arena not only for student teacher learning but also for building study well-being. It provides a highly socially embedded learning environment. Accordingly, the social support system provided by the teacher education learning environment contributes to student teachers' study well-being (see Cohen, Gottlieb, & Underwood, 2000). Further, social support provides central psychosocial coping resources (Schwarzer & Knoll, 2007; Thoits, 1995) perceived as being available and those that are provided by the social environment (Cohen et al., 2000; Gottlieb & Bergen, 2010; Schwarzer & Taubert, 2002). It has been proposed that social support is a process through which social relationships promote well-being (Brannan, Biswas-Diner, Mohr, Mortazavi, & Stein, 2012; Cohen et al., 2000), and that supportive relationships provide something that an individual needs to adapt to stress (House, Umberson, & Landis, 1988). Lack of support among students, in turn, may contribute to lower study well-being (Chao, 2011) or psychological distress (Chaplain, 2008). The sense of social support, especially at the beginning of a teaching career, is of crucial importance for teachers' meaningful and empowering work experience (Hobson, 2009; Johnson et al., 2013; Pogodzinski, 2013), that may enhance their well-being.

The social support system is here illustrated as a social support model (Pyhältö, 2018) adopted to teacher education (see Figure 1) and consists of sources of support, types of support, support fit and support dynamics connected to each other.

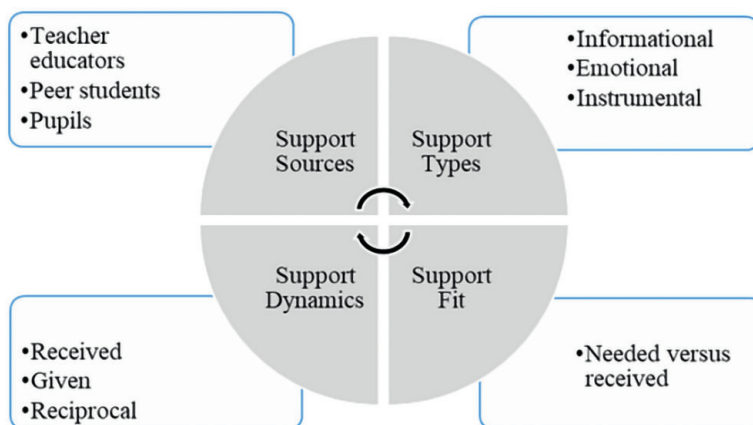

Figure 1. Social support system provided by teacher education (adapted from Pyhältö, 2018).

Social support refers to positive aspects of relationships with others (Gottlieb & Bergen, 2010; House et al., 1988). Teacher education provides a social support system with frequent interactions with peers (Hsu, 2005; Le Cornu, 2009), teacher educators (Murray-Harvey et al., 2000) and pupils (Timošćuk & Ugaste, 2010, 2012) that are central *support sources* for student teachers. Further, this doctoral dissertation examines student teachers' social support in terms of emotional, informational and instrumental *support types* (see Cobb, 1976; Helgeson, 2003; House, 1981; Thoits, 2011) that are available for student teachers in a social support system enabled in a teacher education learning environment to solve different kinds of problems (see Pyh lt , 2018). Emotional support refers to empathy, trust, listening, esteem, caring, encouragement and belonging to a network of communication and mutual obligation (Cobb, 1976; House, 1981; Thoits, 2011). Further, according to Thoits (2011), emotional support from significant others promotes sense of belonging and is effective in protecting well-being, because of the closeness of the relationship. For example, student teachers' sense of belonging and connectedness is enhanced by emotional support from the school community (Rajuan, Beijaard, & Verloop, 2008a, 2008b). Informational support, such as advice and suggestions, is characterised by useful information on how to cope with and to solve personal and environmental problems (Cobb, 1976; House, 1981; Thoits, 2011). Also, this type of support may contain appraisal support, i.e. feedback (Barrera & Ailay, 1983; Thoits, 2011). For example, student teachers are shown to value feedback as an informational social support practice that promotes their learning (Ferguson, 2011; Le Cornu, 2009; Timošćuk & Ugaste, 2012). Finally, instrumental support may diminish demands directly by being directed to practical tasks or problems and offers both behavioural and material assistance (Thoits, 2011), such as time, labour or supplementary materials that help student teachers manage their appointed tasks in their studies (see Cobb, 1976; House, 1981).

The match between the support needed and that received, i.e. *support fit*, is a crucial determinant of experienced well-being (Wolff, Schmiedek, Brose, & Lindenberger, 2013; see also Pyh lt , 2018). It has been shown that the type of support provided should provide resources for coping with the particular stressor faced (Cohen & McKay, 1984; Helgeson, 2003; Helgeson & Gottlieb, 2000). This means that provided support has to match the problem faced to be effective, for example, the appropriateness of the social support and the roles of the giver and receiver of the support are important determinants of the supportive behaviour actualised and thereby useful in the evaluation of whether social support has a positive impact (Cohen & Syme, 1985). Moreover, there might be a lack of support, i.e. mismatched support (see Pyh lt , 2018). Faced challenges with adequate support generate empowerment for student teachers, whereas great challenges without adequate support may diminish their sense of self as a teacher and cause disempowerment to teaching (Tang, 2003). Also, students might feel incompetent if they provide less support to others than needed, and further, may experience this as a source of burdening (Jou & Fukada, 2002).

Typically, social support occurs between the shared network (Gottlieb & Bergen, 2010; Shumaker & Brownell, 1984) that is constructed between individuals in the teacher education learning environment. Receiving and giving social support is expected to be reciprocal by its nature and, for this reason, these *support dynamics* occur primarily in relatively stable social relationships (House, 1981; see also Pyh lt , 2018). In general, informational support is expected of experts (such as teacher educators), while it is not always desired from confidants, and conversely, emotional support may be seen as helpful, whatever its source (Helgeson, 2003). For example, student teachers value su-



supervisor teachers as sources of support during teaching practice (Smith & Lev-Ari, 2005; Timoštšuk & Ugaste, 2010). Student teachers value receiving informational support, such as advice (Hobson, 2002). This includes positive and constructive feedback that provides them with information on their strengths and challenges them to develop their competence to teach (Le Cornu, 2009), i.e. supports their learning to become a teacher. Further, supportive relationship from supervisor teachers may contribute to student teachers' sense of fit into the school environment (Tang, 2003). Even if student teachers see supervisor teachers as important coping resources (Murray-Harvey et al., 2000), they have also been shown to want more support to cope with problems (Timoštšuk & Ugaste, 2012). They call for closer contact with university teachers to receive more support (Timoštšuk & Ugaste, 2010, 2012). Especially, teacher educators are not always identified as a strong source of emotional support (Chaplain, 2008; Kaldi, 2009). Feelings of being unsupported by teacher educators (Chaplain, 2008; Rieg, Paquette, & Chen, 2007; Timoštšuk & Ugaste, 2010) is experienced as stressful (Chaplain, 2008; Rieg et al., 2007). It also evokes negative emotions in learning activities in teacher education (Saariaho et al., 2018) that may challenge study well-being.

Peer student teachers, in turn, are perceived as supportive friends (Hsu, 2005) that have, for instance, a meaningful role in situations that are less positive (Le Cornu, 2009). Beginning teachers, in turn, value socialising with colleagues to develop collaborative working, which promotes networks of emotional support (McCallum & Price, 2010). Further, support received both from peers and supervising teachers enables an encouraging and psychologically safe learning environment for student teachers, whereas a psychologically unsafe environment may hinder productive learning (Tang, 2003; see also Saariaho, Pyhältö, Toom, Pietarinen, & Soini, 2015). Experienced support from teacher educators is also shown to provide triggers for student teachers' learning (Rajuan et al., 2008a).

Previous studies have shown that social support and coping are reciprocally interactive (e.g., Greenglass & Fiksenbaum, 2009). Further, social support may contribute to the choice of the coping strategies (Folkman, 1984; Greenglass & Fiksenbaum, 2009). For example, social support networks are seen as significant for developing and maintaining different coping strategies during teaching practice (Murray-Harvey et al., 2000) while dealing constructively with problems. Essential for study well-being is that student teachers not only identify and utilise the social resources provided by their learning environment but also actively build the relationship between them and their learning environment.

### **1.2.2 Proactive strategies to regulate the risk of burnout**

Student teachers are not only affected by their teacher education learning environment, they can also actively modify it by directing and re-directing their own and others' development and behaviour in a way that promotes positive learning environment dynamics and reduces burnout (e.g., Fernet, Guay, Senecal, & Austin, 2012; Pietarinen et al., 2013a; Soini, Pietarinen, Toom, & Pyhältö, 2015). Student teachers may, for example, adopt and utilise different strategies to cope better with academic and professional stressors they face during their teacher education studies and to modify their learning environment. These coping strategies that students utilise are linked to their study well-being (Carnicer & Calderón, 2014). Seeing difficulties as a problem that can be worked on and changed and to stand for problems in a flexible

way within their working environment is particularly useful for beginning teachers (McCallum & Price, 2010). Furthermore, functional coping strategies can be developed and learnt by beginning teachers, for example through reflection or by being supervised by more-experienced colleagues (Howard & Johnson, 2004).

Traditionally, coping strategies to manage specific demands that are appraised as going over the individuals' resources have been divided into problem-focused coping strategies, including defining the problem and creating alternative solutions to it, and emotional-focused coping strategies directed to regulate emotional responses to the problems, i.e. strategies such as avoiding and distancing (Lazarus & Folkman, 1984). Further, problem-focused strategies are addressed to the environment or at oneself and are aimed at controlling difficulties in the person–environment relationship (Folkman, 1984). Problem-focused strategy use is related to reduced levels of students' academic stress (Renk & Smith, 2007) and it helps them to maintain their study well-being (Chao, 2011). Teachers' utilised problem-focused coping strategies encourage them to focus on actual problems faced and to change these situations, and hence, experience less burnout (Chang, 2013). Teachers' direct-action strategies are actions that can be implemented to remove the source of stress, i.e. the specific sources of stress can be dealt with in the future successfully or to change the situation to remove demands (Kyriacou, 2001).

Teachers' emotional regulation ability may produce positive emotion-using strategies to manage stress (Brackett, Palomera, Mojsa-Kaja, Reyes, & Salovey, 2010), such as cognitive reappraisal (Tsouloupas, Carson, Matthews, Grawitch, & Barber, 2010). Teachers may also use humour or talking about emotions with peers (Sharplin et al., 2010). These strategies diminish the feeling of stress that occurs, i.e. the source of stress is not dealt with directly (Kyriacou, 2001), but these strategies may enable focusing on direct action (Sharplin et al., 2010). On the other hand, as student teachers become highly involved with peer students' problems, they may experience empathic stress, which may contribute to psychological distress (Carnicer & Calderón, 2014). Inadequate use of active strategies may result in increased psychological distress (Carnicer & Calderón, 2014) and further, avoiding thinking about the study problems is linked to lowered study well-being (Chao, 2011; Gustems-Carnicer & Calderón, 2013).

Coping can be examined through time-related classification also, such as reactive and proactive coping (see Schwarzer & Taubert, 2002). Proactive coping includes individuals' efforts to construct and gather general resources (Aspinwall, 2011; Schwarzer & Knoll, 2003), and developing required skills to utilise those (Schwarzer & Taubert, 2002). It has been suggested that students' functioning in their environment is active, including purchasing resources (Gan, Yang, Zhou, & Zhang, 2007). For example, student teachers identify the meaning of building reciprocal relationships with others (Price & McCallum, 2015). Since proactive coping is addressed to preparing in general, and not to a particular stressor, it requires the ability to identify potential stressors beforehand (Aspinwall & Taylor, 1997). Neutralising the stressor before it becomes harmful is shown to be effective (Fortes-Ferreira, Peiró, González-Morales, & Martín, 2006; Pietarinen et al., 2013a). This means that proactive coping is future-oriented and active (Aspinwall & Taylor, 1997; Gan et al., 2007; Greenglass, 2005; Straud et al., 2015), i.e. it refers to initial coping efforts that are made in advance to prevent or modify the potentially stressful events before those occur or to minimise a recognised stressor (Aspinwall, 2011; Aspinwall & Taylor, 1997). However, one may also implement some preparatory activities, as all stressful events cannot be avoided (Aspinwall & Taylor, 1997). Although the use of reactive strategies to classroom management are proposed to be predictors of work-

load or student misbehaviour stress (Clunies-Ross, Little, & Kienhuis, 2008), it has been suggested that teachers' use of reactive strategies may also activate the use of proactive strategies (Bermejo-Toro, Prieto-Ursúa, & Hernández, 2016).

Individuals using proactive coping are active in interpreting potential threats in their environment (Davis & Asliturk, 2011). For example, teachers have been found to use active coping strategies (Sharplin et al., 2010; Shen, 2009) and that teachers using proactive coping see potential risks in their classroom in advance and may be better prepared to address problems (Chang, 2013). Additionally, in proactive coping demands of the environment are seen as challenges, not as threats (Greenglass & Fiksenbaum, 2009; Schwarzer & Taubert, 2002). For example, students have been shown to perceive demanding situations as challenges during their studies (Gan et al., 2007). Further, these challenges are opportunities for personal growth (Folkman, 1984; Schwarzer & Taubert, 2002) and mastery (Folkman, 1984), i.e. student teachers may learn from challenging situations and favour their development as future teachers. Proactive coping is also associated with experiencing life as meaningful (Schwarzer & Knoll, 2003; Schwarzer & Taubert, 2002). The ability to use proactive coping contributes to well-being (Sohl & Moyer, 2009), for example teachers' adopted proactive coping is seen as a protective feature against teacher burnout (Chang, 2013; Pietarinen et al., 2013a; Verešová & Malá, 2012).

Proactive strategies can consist of both self-regulative and co-regulative activities (Pietarinen et al., 2013a). Drawing on the literature on self-regulative learning (Boekaerts, Pintrich, & Zeidner, 2005; Zimmerman, 2002), this dissertation considers self-regulation as referring to student teachers' strategies that are oriented to cope with stressors faced during studies in teacher education. Proactive coping requires an individual's capability to regulate their own thoughts, emotions and behaviours in different potentially stressful situations, i.e. to *self-regulate* (Chang, 2009; see also Boekaerts et al., 2005; Zimmerman, 2002), but also drawing from or building actively social resources that can be utilised, i.e. *co-regulation* (see also Hadwin & Oshige, 2011; Järvelä, Volet, & Järvenoja, 2010), such as asking for help from or providing help to others. For example, the process of coping with feelings of inadequacy in teacher studies is shown to be both individual and collective (Lindqvist et al., 2017).

Managing and using proactive *self-regulative strategies* are meaningful for student teachers to perform as the actors of their own well-being (Price & McCallum, 2015). Further, it reduces effects of stress, for example, to engagement to studies (Gan et al., 2007) during teacher education. In general, proactive self-regulation strategies entail, for example, long-term planning (Aspinwall & Taylor, 1997; Schwarzer & Taubert, 2002), allocating enough time for studying (Randi, Corno, & Johnson, 2011) and being organised (Aspinwall & Taylor, 1997; Straud et al., 2015), when expecting to face potentially stressful transactions (Chang, 2009; see also Boekaerts et al., 2005; Zimmerman, 2002). Proactive coping entails goal setting, also (Greenglass & Fiksenbaum, 2009), for example, student teachers use setting achievable goals as part of their self-regulatory process (Price & McCallum, 2015; Saariaho et al., 2015) and they set realistic expectations for their own performance (Murray-Harvey et al., 2000). Further, student teachers prefer professional strategies, for example during their teaching practice, including self-management skills, e.g., planning, preparation and time organisation to find time for relaxation (Murray-Harvey et al., 2000), i.e. ensuring a good study-leisure balance, as well as employing problem-solving techniques (Price & McCallum, 2015). Also, it has been proposed that student teachers see learning to be prepared for stressful events as resolving experienced feeling of professional inadequacy (Lindqvist et al., 2017).

Student teachers may also build social networks in the teacher education learning environment or seek feedback proactively (see Aspinwall, 2011) and further, social networks may facilitate proactive coping efforts (Aspinwall & Taylor, 1997). Effective proactive coping embodies, for example, seeking information from others (Aspinwall & Taylor, 1997), i.e. *co-regulation strategies*. For example, seeking support from supervisor teachers with whom to talk about problematic situations and to learn from them, is a significant coping strategy for student teachers during teaching practice (Murray-Harvey et al., 2000). Also, in the environments with protective structures, such as collegial support, seeking help from teacher colleagues is used (Sharplin et al., 2010; Shen, 2009), for example, among beginning teachers (Schonfeld, 2001). Typically, teachers, especially those who experience high levels of social support, are reported to use active, problem-focused strategies (Shen, 2009). Further, also student teachers seek social support from their peers (Murray-Harvey et al., 2000; Smith & Lev-Ari, 2005) and hence utilise co-regulation. Peer students are conveyers of professional knowledge or reflective counterparts with whom to share ideas and actions (Hsu, 2005), learning together (Saariaho et al., 2015) and to share experiences (Murray-Harvey et al., 2000). Further, already student teachers see that they need supportive colleagues in their future work to learn more about reacting to stressful events (Lindqvist et al., 2017) co-regulatively. However, beginning teachers themselves may feel isolation since they do not have time to talk to peers or they lack confidence to discuss topics that concern them (McCallum & Price, 2010), i.e. they may lack opportunities to seek help to sustain their well-being. Teachers may enhance their working environment fit by utilisation of co-regulative strategies, i.e. ability to utilise social resources in their working environment and seek help from colleagues (Pietarinen et al., 2013a).

It can be assumed that, to a certain extent, co-regulation can enhance the development of proactive self-regulation (Alarcon, Edwards, & Menke, 2011; Newman, 2008), for instance, by enabling guidance on how to manage the academic workload or through providing a source of information (Alarcon et al., 2011). This is because one may learn possible strategies to resolve problems in the future by themselves (Newman, 2008). On the other hand, proactive co-regulation provides an ability to apply self-regulative strategies (Boekaerts & Corno, 2005; Ford & Blaustein, 2013; Price & McCallum, 2015), because those enable utilisation of the potential sources of social support available and giving support to others (Boekaerts & Corno, 2005; Ford & Blaustein, 2013). For instance, use of self-regulative strategies, such as monitoring one's behaviour (Greenglass, 2005; Hadwin, Järvelä, & Miller, 2011), may result in awareness of the need for help that further launches help-seeking (Ryan, Pintrich, & Midgley, 2001). Moreover, self-regulated learners are shown to be able to recognise the need for support and further be able to seek help from peers (Newman, 2002). There is some evidence that proactive coping is expected to remain stable across different situations (Sohl & Moyer, 2009). However, the use of resources, setting realistic goals and using feedback may vary between situations (Sohl & Moyer, 2009), i.e. different concerns may adduce different types of proactive strategy use (De Ridder & Kerssens, 2003).

### **1.3 SUMMARY OF THE THEORETICAL FRAMEWORK**

In this dissertation study, student teachers' study well-being, referring to subjective evaluations of, for example, quality of relationships with others, sense of own competence as a student and an ability to manage one's own learning environment, as well as

construction and regulation of study well-being, is explored not only as an individual experience but is highly socially embedded in their learning environment. Accordingly, student teachers' study well-being is constructed in the continuous interaction and dynamics between the individual student teacher and his or her learning environment (Maslach, 2003; Maslach & Leiter, 2008), for example between dynamics of demands and resources available (Maslach, 2003; Peeters & Rutte, 2005; Sharplin et al., 2010) (see Figure 2). This dynamics can be explored in terms of the experienced fit, that is match or mismatch, between the student teacher and his or her learning environment. The fit can either support or challenge their study well-being. Student teachers face several stressors during their studies that evolve from their relationship with the learning environment (Folkman, 1984; Kokkinos, 2007), such as heavy workload (Chaplain, 2008; Klassen & Durksen, 2014) and concerns about their own competence (Murray-Harvey et al., 2000). While prolonged, stress that student teachers experience during their studies may even induce burnout (e.g., Freudenberger, 1974; Maslach, 2003; Maslach et al., 2001), i.e. a collection of symptoms of exhaustion, cynicism and inadequacy (Bresó et al., 2007; Maslach et al., 2001; Moneta, 2011; Salmela-Aro & Kunttu, 2010).

Student teachers may construct their study well-being with the presence of social support resources (e.g., Thoits, 1995) that their specific teacher education learning environment enables. This refers to a social support system that is available and provided to them in the teacher education learning environment (see Cohen et al., 2000), including support sources, support types, support fit and support dynamics (Pyhältö, 2018). Teacher educators are seen as an important support source (Murray-Harvey et al., 2000), especially in terms of informational support (Ferguson, 2011; Le Cornu, 2009; Timoštšuk & Ugaste, 2012), whereas peers are seen as sources of emotional support (Murray-Harvey et al., 2000). Further, both teacher educators and peer students are building an encouraging and psychologically safe environment for student teachers' learning throughout support (Tang, 2003). However, there needs to be a match between the support needed and that received, which refers to support fit, for the experienced well-being (Wolff et al., 2013; see also Pyhältö, 2018).

Furthermore, the learning environment fit may be actively modified by directing one's own and others' development and behaviours in a way that promotes positive learning environment dynamics and reduces burnout (Fernet et al., 2012; Pietarinen et al., 2013a; Soini et al., 2015). For example, proactive coping includes student teachers' efforts to construct and purchase general resources actively (e.g., see Aspinwall, 2011; Gan et al., 2007; Schwarzer & Knoll, 2003) to enhance and regulate their study well-being. Hence, student teachers may utilise active proactive strategies that consist of both self-regulative and co-regulative activities (see Pietarinen et al., 2013a). They may, for example, actively allocate time for studying (Randi et al., 2011), set achievable goals (Price & McCallum, 2015) or seek support from their peer students (Smith & Lev-Ari, 2005) and teacher educators (Murray-Harvey et al., 2000).

Further, it can be suggested that gathering social resources and utilising strategies may be learnt already during teacher education. It has been proposed that teachers can develop and learn functional coping strategies (Howard & Johnson, 2004) and that student teachers understand the need for supportive colleagues in the teaching profession to learn, for example, responding to stressful situations (Lindqvist et al., 2017). However, student teachers may learn to purchase resources in their learning environment and to utilise functional strategies to support their well-being in studies and to avoid possible mismatches between them and their learning environment.

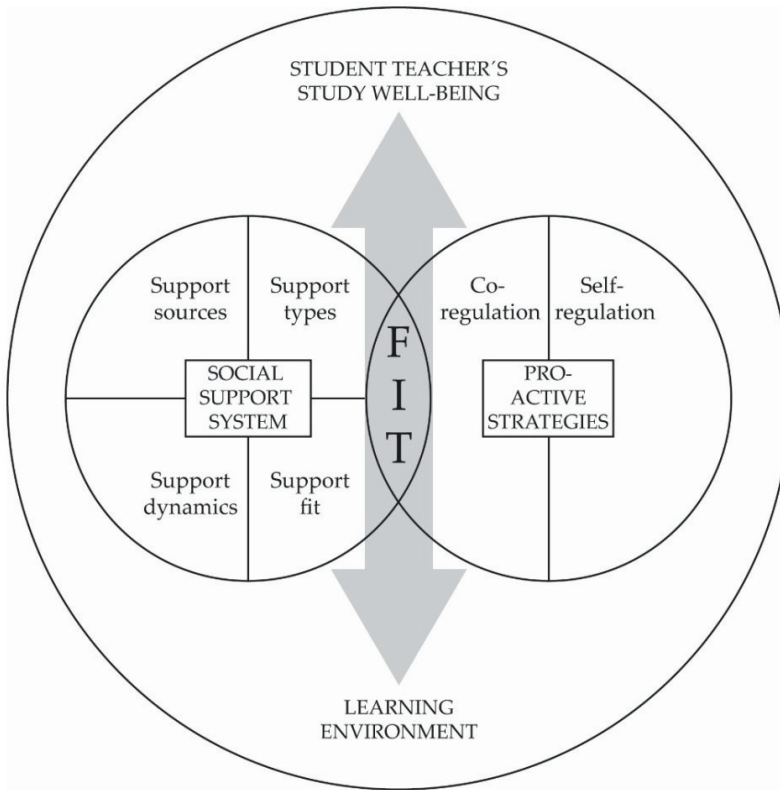

Figure 2. A visualisation of the key concepts of the study.

## 2 THE AIM OF THE STUDY

The overall aim of the dissertation study was to understand the construction of the student teachers' experienced study well-being and how it is regulated during teacher education studies. The study focused on exploring the kind of social support system available for student teachers in their teacher education learning environment promoting their study well-being. Moreover, the dynamic interplay and the stability between student teachers' proactive strategy use, experienced learning environment and risk of study burnout during teacher education were examined. The following research questions were addressed:

1. How does social support contribute to student teachers' experienced well-being? (*Study I*)
2. How do proactive strategies regulate student teachers' risk of study burnout? (*Study II and III*)
3. What kinds of interrelations are there between student teachers' proactive strategies, perceived learning environment and risk of study burnout? (*Study III*)
4. How stable and predictable are the interrelations between proactive strategies, perceived learning environment and risk of study burnout during bachelor-phase studies? (*Study III*)

This dissertation is comprised of three sub-studies (*study I, II and III*). *Study I* focused on deepening the understanding of the dynamics and quality of the social support system adopted in teacher education and its significance for student teachers' experienced well-being. The extent to which student teachers face empowering and burdening situations constructed by the quality of informational, emotional and instrumental support enabled among primary school and secondary school student teachers during their teacher studies was investigated. After that, student teachers' utilised proactive self- and co-regulative strategies to regulate study well-being was explored in two separate studies, both cross-sectionally and longitudinally, to examine both individual and interactive ways to regulate one's own and others' well-being during the first years of studies. More specifically, *study II* explored the interrelations between the proactive strategy use and risk of study burnout experienced by primary school student teachers at the beginning of their studies. Interrelations were investigated between proactive strategies as a whole and exhaustion in studies, inadequacy in studying and cynicism towards studies. *Study III* aimed to deepen the exploration of the dynamic interrelations between bachelor-phase student teachers' proactive self-regulative and co-regulative strategies and learning environment and how those regulate and construct student teachers' risk of study burnout. Also, stability and predictability were investigated to examine the development of these constructions during the first three years of teacher studies. A summary of the aims, research questions and hypotheses is presented in Table 1.

Table 1. Summary of the overall aim, research questions and the sub-study research questions and hypotheses for *studies I, II and III*.

| OVERALL AIM  | RESEARCH QUESTIONS  | STUDY                   | SUB-STUDY RESEARCH QUESTIONS AND HYPOTHESES  |
|--|---|-------------------------|--|
| <p>To understand the dynamic construction and regulation of the student teachers' experienced study well-being in terms of social support, proactive strategies and learning environment</p> | <p>1) How does social support contribute to student teachers' experienced well-being?</p> <p>2) How do proactive strategies regulate student teachers' risk of burnout?</p>       | <p><i>Study I</i></p>   | <p>How does the social support system enabled during teacher studies contribute to student teachers' experienced well-being?</p> <ul style="list-style-type: none"> <li>• What types of support contributing to student teachers' experienced empowerment (and burdening) can be identified during teacher studies?</li> <li>• How do the student teachers perceive appropriateness of the social support functions enabled in teacher education?</li> <li>• To what extent do the student teachers experience receiving, offering and having reciprocity in various types of support during their studies?</li> <li>• What are the main sources of student teachers' social support?</li> </ul>   |
|  | <p>3) What kinds of interrelations are there between student teachers' proactive strategies, perceived learning environment and risk of study burnout?</p>                        | <p><i>Study II</i></p>  | <p>How do the proactive strategies regulate student teachers' risk of study burnout at the beginning of teacher studies?</p> <ul style="list-style-type: none"> <li>• H1: Proactive self- and co-regulative strategies regulate student teachers' cynicism towards studies, the experienced exhaustion in studies and the inadequacy in studying.</li> <li>• H2: Experienced exhaustion in studies and inadequacy in studying regulate cynicism towards studies.</li> </ul>  |
|  | <p>4) How stable and predictable are the interrelations between proactive strategies, perceived learning environment and risk of study burnout during bachelor-phase studies?</p> | <p><i>Study III</i></p> | <p>How does proactive strategy use contribute to the perceived learning environment and the risk of study burnout during bachelor phase studies?</p> <ul style="list-style-type: none"> <li>• H1: Self-regulative strategy correlates [positively] with student teachers' co-regulative strategy at every time point (within T1, T2 and T3).</li> <li>• H2: Self-regulative strategy and co-regulative strategy correlates [negatively] with student teachers' experienced study-related burnout at every time point (within T1, T2 and T3).</li> <li>• H3: Co-regulative strategy correlates [positively] with the perceived learning environment in teacher education, which, in turn, further correlates [negatively] with experienced study-related burnout at every time point (within T1, T2 and T3).</li> </ul> |



## 3 METHODS AND PROCEDURES

This dissertation draws on ideas of mixed methods research (e.g., Creswell, 2014; Tashakkori & Teddlie, 2016) and combines both qualitative and quantitative methods in the data collection and analysis in the series of three sub-studies that investigate student teachers' study well-being (Leech & Onwuegbuzie, 2009). Further, mixed methods research may be seen as a practical synthesis, which is based on both quantitative and qualitative research (Johnson, Onwuegbuzie, & Turner, 2007). Mixed methods research allows a deeper and better understanding of the explored phenomenon (Johnson et al., 2007) of student teachers' study well-being during teacher education, since the same overall aim is studied with different approaches utilised in sub-studies. Even if different studies are conducted by applying one method separately, i.e. either qualitative or quantitative, the focus group is in the same context, i.e. student teachers in Finnish teacher education.

The mixed method approach draws on pragmatism (Creswell, 2014; Creswell & Plano Clark, 2017; Johnson & Onwuegbuzie, 2004; Johnson et al., 2007) and hence the selection of methods is chosen to answer the research questions in the optimum way (Johnson & Onwuegbuzie, 2004; Johnson et al., 2007). A pragmatic approach to the research aim includes both the natural and physical world as well as the social and psychological world with examinees' subjective thoughts (Johnson & Onwuegbuzie, 2004). Further, pragmatism is oriented to real-world practice (Creswell & Plano Clark, 2017). Knowledge, truth and meaning are seen as changing over time (Johnson & Onwuegbuzie, 2004).

Due to the mixed methods approach in this study, some dimensions of triangulation were utilised in order to enhance the quality of research (Krefting, 1991). Regarding methodological triangulation, in this study both qualitative and quantitative methods were utilised to investigate the same phenomenon (Cohen, Manion, & Morrison, 2011). Furthermore, both cross-sectional and longitudinal research was utilised, i.e. time triangulation (Cohen et al., 2011). In the cross-sectional part of the study, student teachers' proactive strategies and burnout symptoms were studied at the beginning of the studies. The longitudinal research frame broadened the examination to the learning environment, also, and comprised the bachelor phase. Qualitative semi-structured interviews considered the whole study path. In conclusion, two separate data collections and analyses were made and after that the results of the sub-studies were combined and interpreted in the Discussion section (e.g., see Gelo, Braakmann, & Benetka, 2008).

### 3.1 TEACHER EDUCATION IN FINLAND

In Finland, all primary and secondary school teachers must have a master's degree. Primary school teachers typically teach grades 1–6 (age 7–13). Some primary school student teachers will study a minor subject (60 credits) from a particular subject taught in comprehensive school, which justifies a qualification to teach grades 7–9. Subject teachers can work as upper comprehensive school teachers in grades 7–9 (age 13–16) or upper secondary school (age 16–19) teachers.

Higher education is publicly funded in Finland and free of charge for students. There are eight universities that educate for educational science teacher education. Teacher education is research based and research intensive including a master's thesis (Niemi & Jakku-Sihvonen, 2011; Toom et al., 2010; Westbury, Hansén, Kansanen, & Björkvist, 2005). Teacher education follows the Bologna process (Niemi & Jakku-Sihvonen, 2011; Opettajankoulutus 2020, 2007). In accordance with the Bologna process, the Bachelor's degree is a lower university degree, in which studies contain 180 European Credit Transfer and Accumulation System (ECTS) credits that can be carried out in three years by studying full-time (Valtioneuvoston asetus yliopistojen tutkinnoista 794/2004). A master's degree, which requires completion of 120 credits, follows this and can be earned in two years (Valtioneuvoston asetus yliopistojen tutkinnoista 794/2004).

Applicants for the primary school teacher education programme are selected via a two-phase entrance examination (Selvitys opettajankoulutuksesta 14.11.2011). The VAKAVA-exam (the Finnish acronym for National Educational Selection Cooperation Project) is open for those eligible for higher education and focuses on applicants' academic studying skills in educational sciences. After this, some applicants are invited to the second phase of the examination based on their score from the first-phase. The second phase is the so-called aptitude test, where applicant suitability is tested, for example, via individual and group interviews (Selvitys opettajankoulutuksesta 14.11.2011). Primary school teacher education is one of the most popular university study programmes (Niemi & Jakku-Sihvonen, 2006a; Niemi & Jakku-Sihvonen, 2011; Selvitys opettajankoulutuksesta 14.11.2011). In most Finnish universities, approximately 10–15 % of applicants are approved for teacher education programmes (Niemi & Jakku-Sihvonen, 2006a; Niemi & Jakku-Sihvonen, 2011) and entry into teacher education is highly competitive (Malinen, Väisänen, & Savolainen, 2012). Hence, the student teachers are highly motivated (Niemi & Jakku-Sihvonen, 2011) and diligent (Niemi & Jakku-Sihvonen, 2006b). Also, study attrition within teacher studies is low (Niemi & Jakku-Sihvonen, 2006a). The majority of the student teachers are female (see Opetushallitus, 2017; Tilastokeskus, 2018). Students enter university through various routes. Some of them continue their tertiary studies immediately after upper secondary schools, while others apply for university studies following several years of working life.

The class-teacher programme student teachers' majors are either educational science or less frequently educational psychology, which is 140 credits including 20 credits of supervised teaching practice. Supervised teaching practice is carried out at specific training schools, that are schools affiliated with the Educational Science Faculties and Departments (Niemi & Jakku-Sihvonen, 2011), or in lesser extent other schools approved by the university (Valtioneuvoston asetus yliopistojen tutkinnoista 794/2004). Teaching practice aims to bring together theoretical knowledge and practice and further, to support student development into experts that examine and develop their own work (Opettajankoulutus 2020, 2007). The degree also consists of orientation studies (25 credits), multidisciplinary studies of various subjects and cross-curricular issues covered in comprehensive school (60 credits) and optional minor subject and optional studies (75 credits). Multidisciplinary studies of various subjects and cross-curricular issues covered in comprehensive school provide professional readiness to teach these subjects and cross-curricular issues included for all pupils at comprehensive school (Valtioneuvoston asetus yliopistojen tutkinnoista 794/2004).

Also, subject student teachers complete pedagogical studies (60 credits, including 20 credits of teaching practice) that include educational science studies emphasised didactically as well as supervised teaching practice alongside their main studies (Niemi & Jakku-Sihvonen, 2006a; Niemi & Jakku-Sihvonen, 2011; Valtioneuvoston asetus yliopistojen tutkinnoista 794/2004) over either one year or several years. Usually, subject student teachers apply to study the subject they will teach and after this they apply to fulfil teachers' pedagogical studies (Selvitys opettajankoulutuksesta 14.11.2011).

## 3.2 PARTICIPANTS

Participants in this dissertation study included student teachers from three Finnish universities and they formed qualitative student teacher data and quantitative student teacher data. They were at different phases of their studies.

In *study I*, the participants were 40 final-stage student teachers studying at a research-intensive Finnish university. 27 of the participants were female (67.5 %) and 13 were male (32.5 %). The student teachers' ages varied between 24 and 54 years, the mean age being 30.2. 19 of them were primary school student teachers and 21 student teachers in subject teaching. Criteria for participant selection was the following: estimated graduation time within one year, professional orientation as interest in working in a comprehensive school after graduation and education as a major subject for primary school student teachers or teachers' pedagogical studies for subject student teachers. Subject student teachers' main subject varied, and they were studying, for example, biology or mathematics.

Participants of *studies II* and *III* were the same primary school student teachers and they came from three Finnish universities. Quantitative data collection was carried out with non-probability sampling (see Cohen et al., 2011), and this subpopulation was chosen according to its accessibility (Gelo et al., 2008), which improved the possibility to perform longitudinal research and reach participants. The criterion for selection to *studies II* and *III* was that they had started their studies in the autumn of 2012. In *study II*, 244 first-year primary school student teachers completed the survey (female: 186/76.2%; male: 58/23.8%). Participants' average age was 24.2 years varying between 20 and 46 years. The total response rate among student teachers was 83 %. *Study III* consisted student teachers during their bachelor phase in teacher education. Some of these student teachers were also studying for the qualification to teach at upper comprehensive school as subject teachers. The total response rate was at T1 83 %, T2 55 % and T3 57 %. At time 1 (N = 270) there were 211 (78.1 %) female and 59 (21.9 %) male participants. Participants' average age was 23.9 years varying from 20 to 46. At time two (N = 180) there were 133 (73.9 %) female and 47 (26.1 %) male participants. Average age was 24.3 years and it varied between 21 and 47 years. At the last measurement time (N = 186) there were 139 (75.1 %) female and 46 (24.9 %) male participants. Their average age was 25.2 years varying between 22 and 48. The non-response analysis showed that the sample represented the student population within the universities sufficiently in terms of gender. A more detailed summary of descriptive statistics of all three studies is presented in Table 2 below.

Table 2. Response rates, gender and age at *study I*, *study II* and *study III* (time 1, 2, and 3).

|                     |         | <i>Study I</i> | <i>Study II</i> | <i>Study III</i> T1 | <i>Study III</i> T2 | <i>Study III</i> T3 |
|---------------------|---------|----------------|-----------------|---------------------|---------------------|---------------------|
| Response rate (N/%) |         |                | 244/83%         | 270/83%             | 180/55%             | 186/57%             |
| Gender n/%          | women   | 27/67.5        | 186/76.2        | 211/78.1            | 133/73.9            | 139/75.1            |
|                     | men     | 13/35.5        | 58/23.8         | 59/21.9             | 47/26.1             | 46/24.9             |
| Age                 | min/max | 24/54          | 20/46           | 20/46               | 21/47               | 22/48               |
|                     | M (SD)  | 30.2           | 24.2 (5.23)     | 23.9 (5.04)         | 24.3 (4.37)         | 25.2 (4.41)         |
|                     | Md      | 27             | 22              | 22                  | 23                  | 24                  |
|                     | Mo      | 25             | 21              | 21                  | 21                  | 24                  |

### 3.3 MATERIALS

In this dissertation, both self-reported interviews and surveys were conducted to capture data, in the optimum way (see Johnson & Onwuegbuzie, 2004; Johnson et al., 2007), on the multidimensional nature of student teachers' study well-being and how it is constructed and regulated in different phases of teacher education studies.

#### 3.3.1 Interview data

Participants of the qualitative study (*study I*) were informed by the member of research group in 20 distinct groups, after which students decided their voluntary participation based on introduction. The semi-structured interviews (e.g., Kvale, 2007) were conducted during the spring 2011 (primary school student teacher) and 2012 (subject student teacher), in connection with the research project of 'Learning and Development in School' research group. Participants were interviewed face-to-face, one at a time. A version of the Teacher's Professional Landscape Inventory (Soini et al., 2010) was modified for the teacher education context (Ahonen, Pyhältö, Pietarinen, & Soini, 2015) (see Appendix 1). Four pilot interviews, which were not included in the data, were carried out to validate the interview protocol before actual interviews. The durations of the interviews varied between 33 and 120 minutes. The interviews were audio-recorded digitally and decoded into text files by the members of the research group and trained research assistants.

Interviews included questions about the student teachers' key experiences, such as positive and negative occurrences in teacher education. Also, there were questions about teacher education learning environment and the importance of professional community. Altogether, 16 questions about teacher educational studies and viewpoint of the teachers' work at school were included in the interviews. Additionally, four questions about personal and professional backgrounds were asked. The interviews focused on retrospective recall of student teachers' previous experiences during their

study path in teacher education but also views of their future work visions (e.g., Cox & Hassard, 2007). In this study, the focus was on teacher studies, excluding future work visions. The construction of semi-structured interviews enabled space for interviewees' own voices and experiences (Kvale, 2007) with asking questions in a suitable order and asking corrective questions if needed. In addition, interviewees were asked to draw a visual representation about pivotal occurrences during their study path and to identify and tag both positive, promoting events and negative, hindering events that made a difference in their studies. In this study, those pictures had only a supportive role for interview, i.e. those pictures were not subjected to analysis.

### 3.3.2 Survey data

Quantitative data in *studies II* and *III* were collected during face-to-face lectures by the members of research group. The purpose of the study was explained to participants. Participation was voluntary, and students were able to interrupt filling in the questionnaire at any time. The questionnaire and an information letter were sent to those students who were not reached during lectures and they were asked to fill out the questionnaire and send it back to researchers. Data for *study II* were collected during the spring of 2013. By that time, first-year student teachers had studied a while and had experiences of different practices and even challenges during their studies. They presumably had a more genuine picture of the demands of the studies as well as about burdening and strategy use than at the very beginning of the studies. Longitudinal data for *study III* were collected annually at the same time springs of 2013–2015, i.e. there were three measurements. It took approximately 20 minutes to complete the survey.

The instrument used was based on the Socio-Contextual Teacher Burnout Inventory (STBI) (see Pietarinen et al., 2013a, 2013b) and was modified for student teachers. More specifically, the used instrument was focused on student teachers' burnout symptoms related to studying in teacher education learning environment. The used instrument was constructed and the data were collected by the research group. The instrument was pilot tested before actual data collection in a teacher education unit in Finland, which was not a part of the universities involved in the study. A part of questionnaire utilised in this study contained Likert-type statements focusing on study burnout, proactive strategies and learning environment (see Appendices 2 and 3). In *study II* used scales were the Proactive Strategy and the Student Teacher Burnout scale, whereas in *study III* there were all three scales.

The *Student Teacher Burnout* scale (STB) drew both on Maslach and Jackson's (1981) burnout scale and Elo, Leppänen, and Jahkola's (2003) single-item stress scale that measures perceived exhaustion. The STB scale consisted of eight items measuring three factors of student teacher burnout in teacher studies: a) *exhaustion in studies* (3 items, e.g., *I feel quite burnt out.*), b) *inadequacy in studying* (3 items, e.g., *I often have feelings of insufficiency in my studies.*) and c) *cynicism towards teacher studies* (2 items, e.g., *It is difficult for me to find a clear meaning for my studies.*). All items were rated on a 7-point Likert-type scale ranging from 1 (completely disagree) to 7 (completely agree), excluding the stress item, which was rated on a 10-point scale. In *study II* exhaustion, inadequacy and cynicism were treated separately. Whereas, in *study III* these three symptoms were treated as a unidimensional construct (see also Carmona, Buunk, Peiró, Rodríguez, & Bravo, 2006; Salmela-Aro et al., 2009).

The *Proactive Strategy* scale was based on the research evidence showing that functional proactive strategies for reducing exhaustion, inadequacy and cynicism can be adopted (Chang, 2013; Pietarinen et al., 2013a). The scale consisted of seven items measuring two factors of proactive strategies: a) *self-regulative strategy* (4 items, e.g., *I know how to delimit my studying.*), and b) *co-regulative strategy* (3 items, e.g., *I know how to support my fellow students who are burdened by studies.*). A 7-point Likert-type scale ranging from 1 (completely disagree) to 7 (completely agree) was used to measure proactive strategies student teachers utilise.

The *Learning Environment in Teacher Education* scale (Soini et al., 2015) drew on previous studies on beginning teachers' experiences of teacher education (Ingvarson, Beavis, & Kleinhenz, 2004; Lipponen & Kumpulainen, 2011; Watt & Richardson, 2008). The scale consisted of nine items measuring four aspects of the learning environment: a) *social support* (3 items, e.g., *I receive encouragement and support from teacher educators.*), b) *equality in teacher education* (2 items, e.g., *I am treated equally.*), c) *climate* (2 items, e.g., *There is a good atmosphere for studying in teacher education.*), and d) *recognition from teacher educators* (2 items, e.g., *I feel that teacher educators appreciate my efforts in studying.*). All the items were rated on a 7-point Likert-type scale ranging from 1 (completely disagree) to 7 (completely agree).

### 3.4 ANALYSES

In this dissertation research, both qualitative and quantitative analysis were utilised to explore student teachers' study well-being in terms of empowerment, burdening, study burnout, proactive strategies and learning environment. Data of *study I* were analysed with qualitative content analysis, whereas data of *studies II* and *III* with structural equation modeling (SEM). Furthermore, research began with a more exploratory approach and continued with confirming, deductive approach to reach the overall picture of the construction and regulation of the student teachers' study well-being at the different phases on their study path.

#### 3.4.1 Interview study I

*Study I* utilised a qualitative content analysis (Bengtsson, 2016; Elo & Kyngäs, 2008; Schilling, 2006). The analysis was accomplished with the ATLAS.ti software (version 5.2). The content analysis was divided into three complementary phases (see also Schreier, 2012), which are visualised in Figure 3. At first, all the interview transcripts (N = 40) were read through several times to get an overall understanding of the data and further, initial ideas were noted (Bengtsson, 2016; Braun & Clarke, 2006). After becoming familiar with the data, all the text segments in which students refer to social support or lack of it were coded systematically across the data set in terms of pairs of criteria. These criteria involved 1) social support or lack of social support, and 2) empowering or burdening experience, i.e. all the coded text segments included the both criteria. During this phase, data subjected to analysis was become tighter.

After this, in the second phase, the analysis focused on identifying various functions of social support. Episodes were coded into three main-categories via theory-driven content analysis (e.g., MacFarlane & O'Reilly-de Brún, 2011), meaning that the features that guided the coding were based on prior studies. Theory-driven content

analysis was used when the structure of analysis was operationalised based on previous research, such as categorising types of social support. Further, in order to examine and identify the types of social support in a more detailed way, House's (1981) and Cobb's (1976) seminal work and definitions to qualify the coding frame was used and the text segments were categorised into three main categories, according to student teachers referring to informational, emotional and instrumental support. These different types of support were coded systematically across entire data segments, which came up in the first phase.

In the third phase, the main categories were coded into nine identified subcategories, i.e. text segments illustrating appropriateness of the support (appropriate, not appropriate and lack of support), direction of the support (receive, reciprocal and offer) and the context in which social support occurred (teacher educator, peer student and pupil in school). Also, the potential differences between primary and secondary school student teachers were examined in terms of described main and subcategories.

At the end of the analysis, relationships of the categories were examined. The categories were quantified by counting the number of times (frequencies) the text segments of each category appeared in the data. Frequencies of the coded categories were re-examined in terms of social support types (see Tables 4, 5 and 6). Validation of the criteria for each category was discussed by the research group at the end of each phase of the conducted analysis (Miles & Huberman, 1994). Also, the saturation of the observed contents within the data was examined, and further, the developed categories were approved when the data begun to repeat the same contents within each category (e.g., Hennink, Kaiser, & Marconi, 2017; Saunders et al., 2018).

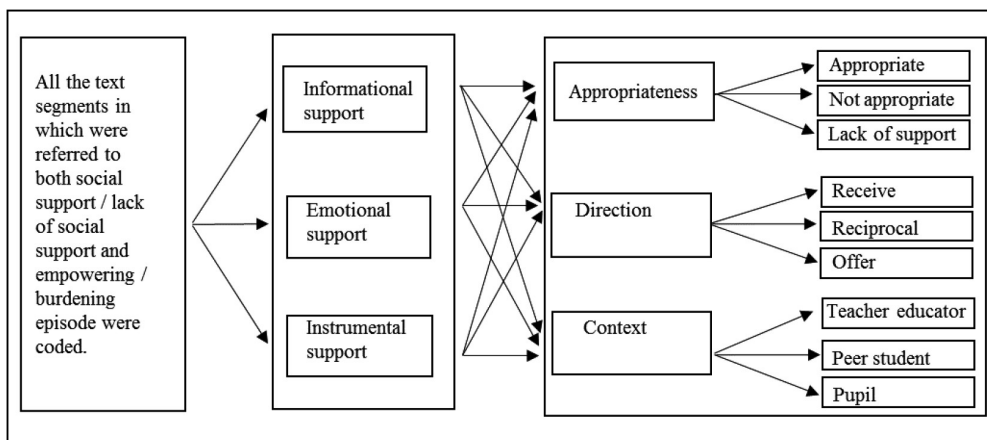

Figure 3. A visualisation of the analysis process in *study I*.

### 3.4.2 Survey studies II and III

In *studies II* and *III* the main analysis method was structural equation modeling (SEM) to analyse interrelations and stability of the proactive strategies, learning environment and study burnout symptoms (e.g., Bowen & Guo, 2011; Schreiber, Nora, Stage, Barlow, & King, 2006; Selig & Little, 2012). Statistical analyses were accomplished

with Mplus (version 5.0; Muthén & Muthén, 1998–2017). Also, the correlations were examined with SPSS software (version 21).

Quantitative data included both cross-sectional data concerning the beginning of the studies and longitudinal data concerning the bachelor phase of the studies. In *study II*, cross-sectional data collected at one point in time were utilised, whereas *study III* utilised longitudinal data collected from the same group at three points in the time sequence (see Cohen et al., 2011). At first in *study II*, confirmatory factor analysis was utilised to form a measurement model with latent factors for proactive strategies and dimensions of burnout. The factor of proactive strategy was a second-order factor formulated by self-regulative and co-regulative strategy. In this sub-study, the structure and combination of proactive strategies (i.e. self- and co-regulative strategy), which regulate perceived study well-being was studied. Also, separate factors for three dimensions of burnout were formulated to enable more detailed analysis of the dimension of burnout risk and interrelations between them and proactive strategies during teacher education. At the second phase, a structural model was formed to see interrelations between detected variables, latent factors, as well as detected variables and factors (see Schreiber et al., 2006). After this, goodness of fit of the path analysis was estimated.

In the longitudinal study (*study III*), variables were measured repeatedly, annually between years 2013–2015. Measurements were carried out in spring nearly at the same point of time. Participants as well as measured variables were the same from measurement to measurement. At first, non-parametric tests with SPSS, Friedman's ANOVA, was used to explore potential differences between means. After this, mean variables for self-regulative strategy, co-regulative strategy, learning environment and burnout were used to test path analysis with Mplus because of the complexity of the model. In this analysis, also the interrelation between self-regulative and co-regulative strategy was examined, in contrast to *study II*, to analyse the development. The structure of the burnout symptoms was examined more closely in *study II*. In turn, in *study III* the three symptoms that raise the risk of study burnout (i.e. exhaustion, inadequacy and cynicism) were treated as a unidimensional construct suggested by the previous studies (Carmona et al., 2006; Salmela-Aro et al., 2009) to simplify the longitudinal path model. In *study III*, the longitudinal analysis missing data method was used, which maximises the sample size by using all the information available to estimate parameters (see Muthén & Muthén, 1998–2017). Finally, goodness of fit of the path analysis was estimated.

The parameters of models in *studies II* and *III* were estimated by using the Robust Maximum Likelihood (MLR) estimator that notices potential non-normality of the parameters (Kline, 2015). Model fit for path analysis in *study II* and *III* was estimated by five goodness-of-fit indices:  $\chi^2$  test, Comparative Fit Index (CFI), Tucker-Lewis Index (TLI), Root Mean Square Error of Approximation (RMSEA), and Standardized Root Mean Squared Residual (SRMR) (Muthén & Muthén, 1998-2017; Schreiber et al., 2006). These fit indices have cut-offs, that indicate the goodness of the model to the data;  $\chi^2$  test  $p$  value  $> 0.05$ , CFI  $\geq 0.95$ , TLI  $\geq 0.95$ , RMSEA  $< 0.06$ , and SRMR  $\leq 0.08$  (Hooper, Coughlan, & Mullen, 2008; Hu & Bentler, 1999; Kline, 2015; Muthén & Muthén, 1998–2017; Schreiber et al., 2006).



### 3.5 SUMMARY OF THE METHODS

To achieve the overall research aim and to answer the research questions addressed in this dissertation research, this study was carried out by collecting data through both qualitative and quantitative methods, i.e. features of mixed method research were utilised to examine the phenomenon comprehensively. Further, both cross-sectional and longitudinal quantitative data were utilised. Data were analysed by using qualitative and quantitative analysis, i.e. content analysis and statistical procedures. A summary of the general aims, participants, methods and procedures used in each sub-study is presented in Table 3.

Table 3. Summary of the methodological choices in the three sub-studies.

| STUDY | GENERAL AIM   | PARTICIPANTS  | DATA SOURCE                        | INSTRUMENT   | ANALYSIS   |
|-------|---|---|------------------------------------|--|--|
| I     | To explore the dynamics of the social support system and its significance for the student teachers' experienced well-being                          | Primary and secondary school student teachers (N = 40)                  | Semi-structured interview          | An interview examining student teachers' key experiences, such as positive and negative occurrences, in teacher education              | Qualitative, content analysis                                      |
| II    | To explore the use of proactive strategies in buffering study burnout among student teachers  | Primary school student teachers (N = 244)                               | Survey                             | Student Teacher Burnout scale (8 items), Proactive Strategy scale (7 items)  | Quantitative, structural equation modeling (SEM)                   |
| III   | To explore the interrelation and the development of student teachers' proactive coping strategies, perceived learning environment and study burnout | Primary school student teachers (T1: N = 270, T2: N = 180, T3: N = 186) | Survey, three-year follow-up study | Student Teacher Burnout scale (8 items), Proactive Strategy scale (7 items), Learning Environment in Teacher Education scale (9 items) | Quantitative, Friedman's ANOVA, structural equation modeling (SEM) |

## 4 RESULTS

The most central results of the three sub-studies are presented. The results are described in more detail in the original journal articles.

### 4.1 SOCIAL SUPPORT AS A CONTRIBUTOR TO STUDENT TEACHERS' EXPERIENCED WELL-BEING (STUDY I)

The first study focused on exploring student teachers' social support system and enabled formal and informal social support during teacher education. Student teachers reported both empowering ( $f = 100$ ) and burdening ( $f = 49$ ) experiences entailing social support or lack of it. Further, the results indicated that experienced formal and informal social support during teacher education can be divided into informational ( $f = 94$ ), emotional ( $f = 50$ ) and instrumental ( $f = 5$ ) types of support. Experienced match between the type of support and the appropriateness of support promoted student teachers' empowerment. Further investigations indicated that primary school and subject student teachers experienced social support practices similarly.

Student teachers reported most frequently *informational support* practices including both empowering ( $f = 55$ ) and burdening ( $f = 39$ ) experiences. Appropriate support was empowering, whereas non-appropriate support or lack of support raised the level of burdening. Typically, appropriate support was received and it occurred mainly in the formal context with teacher educators, i.e. university teachers or teaching practice supervisors (see Table 4). Student teachers, for example, highlighted the value of instruction and advice as well as confirming feedback that supported learning.

*My second supervisor was maybe the best thing in the whole teaching practice. Like (s)he was just, like, superb. -- I had two supervisors in that same teaching practice, so it was the best like what has ever been happened. Like a person who just can be open-minded to all suggestions and ideas and be capable of steering like that. That, you know, when (s)he asks a question, there is only one right answer, but when you get to say it by yourself, so it feels so much better. The person who has that kind of discretion about that, how to supervise, and also that knows how to give feedback in the way that it's easy to receive. Somehow that kind of person that creates self-confidence in you. Like 'show me what you've got', and 'how we put this'. And then it's like 'well, I thought like this'. And like 'good, there it is'. That to find those things and know how to supervise, so it's like really a superb experience. It was really nice, and there [it] was good to end that autumn. Somehow it remained that kind of feeling that- Yeah. (Subject student teacher/appropriate/receive/teacher educator)*

Also, peer student teachers and pupils at school were perceived as sources of informational support, however, to a lesser extent. Conversely, professionally empowering reciprocal informational support ( $f = 8$ ) was more typical between student teachers.

Student teachers also experienced mismatch between support needed and that which was provided, i.e. it was perceived as less appropriate and hence burdening. Also, non-appropriate informational support was experienced from teacher educa-

tors in the form of feedback conversations, which were experienced as destructive and further increased student teachers' sense of inadequacy. The lack of received informational support, expected typically from teacher educators, was experienced as burdening. Furthermore, results indicated that lack of informational support disempowered student teachers and alienated them from meaningful learning processes.

Table 4. Student teachers' sense of informational support.

| APPROPRIATENESS          | DIRECTION          | CONTEXT  |
|--------------------------|--------------------|--|
| Appropriate (f = 55)     | receive (f = 48)   | teacher educator (f = 43)<br>peer student (f = 5)<br>pupil (f = 3) |
|                          | reciprocal (f = 8) | teacher educator (-)<br>peer student (f = 8)<br>pupil (-)          |
|                          | offer (f = 1)      | teacher educator (-)<br>peer student (f = 1)<br>pupil (-)          |
| Not appropriate (f = 14) | receive (f = 14)   | teacher educator (f = 14)<br>peer student (-)<br>pupil (-)         |
|                          | reciprocal (-)     | teacher educator (-)<br>peer student (-)<br>pupil (-)              |
|                          | offer (-)          | teacher educator (-)<br>peer student (-)<br>pupil (-)              |
| Lack of support (f = 25) |                    | teacher educator (f = 23)<br>peer student (f = 2)<br>pupil (-)     |

(f) = number of mentions; (-) = not mentioned

Student teachers reported also *emotional support*. Results showed that student teachers experienced not only empowering emotional support but also a scarce amount of lack of emotional support, which was the source of burdening. Emotional support was received mainly from peer students (f = 18), who provided a meaningful social support system for sharing and solving problems at a deeper level (see Table 5). Empowering emotional support was also reciprocal between student teachers (f = 12) and it was associated with close and stable relationships with peers.

*ST: These peer students, that great community was born, and like in all working, so it was that kind of supporting strength. And I hope that they get that kind of feeling to experience in the teacher's room -- That I hope that, like, the open atmosphere that was there [in the teaching practice] remains also later.*

*I: Tell me an example of the things you shared.*

*ST: Well, of course, all the joys and sorrows like in these situations. Some lesson went a bit "under the bench", but then there was this kind of backing support. Like, well, so it went from us too. And maybe, like, we talk about that, what happened. And then basically we laugh intermittently, that [we] can laugh at that maybe – a folly that came up in that situation. That at first [one is] by oneself [in] that folly, [then we] laugh more at that. That we are here to practise. And then, like, well, these things happen to all of us. And, like, you notice that you are not alone. That those things are to be shared and then that we can laugh at those things together. That those mistakes can be stated in the open. That it's not a depressing situation but vice versa: that we should learn to laugh at those. -- Like true empathy that is needed. And then when we are tired, it was surprising to notice that, although there were sometimes, like, eyes crossing and tired[ness] when [we would] do those [lesson plans] and we were really upset -- That we could say that I'm not managing now, I'm, like, worn out -- That thing, when you state that, so it helps, like, to manage again. (Primary teacher student/appropriate/reciprocal/peer student)*

Emotional support, in the form of empathy, trust and encouragement, was received from teacher educators (f = 13) also, whereas emotional support from pupils (f = 5) during teaching practice contributed empowerment by confirming the success of the teacher–student interaction. This indicates that the source of emotional support in the teacher education context is both formal and informal and wider than with informational support.

Conversely, as informational support, emotional support was not reported to be as non-appropriate. However, lack of emotional support (f = 7) was experienced to some extent. These experiences were contributed to by alienation from the peer student social support system. Teacher educators, in turn, were experienced as unapproachable.

Table 5. Student teachers' sense of emotional support.

| APPROPRIATENESS         | DIRECTION           | CONTEXT   |
|-------------------------|---------------------|---|
| Appropriate (f = 43)    | receive (f = 33)    | teacher educator (f = 13)<br>peer student (f = 18)<br>pupil (f = 5) |
|                         | reciprocal (f = 12) | teacher educator (f = 1)<br>peer student (f = 12)<br>pupil (-)      |
|                         | offer (-)           | teacher educator (-)<br>peer student (-)<br>pupil (-)               |
| Not appropriate (-)     | receive (-)         | teacher educator (-)<br>peer student (-)<br>pupil (-)               |
|                         | reciprocal (-)      | teacher educator (-)<br>peer student (-)<br>pupil (-)               |
|                         | offer (-)           | teacher educator (-)<br>peer student (-)<br>pupil (-)               |
| Lack of support (f = 7) |                     | teacher educator (f = 2)<br>peer student (f = 5)<br>pupil (-)       |

(f) = number of mentions; (-) = not mentioned

Compared to informational and emotional types of support, empowering or burdening tangible *instrumental support* was rarely reported (see Table 6). Empowering, appropriate instrumental support was aroused in teaching practice situations where student teacher's sense of efficacy or competence was challenged, and support was received from the teacher educator and peer student. Conversely, lack of instrumental support was perceived as burdening and support was expected from teacher educators. Student teachers, for example, expected assistance with classroom management, like in the following episode:

*Then I went to follow my teaching practice group before the first teaching practice started, and they were awful. They were shockingly awful, and I become more shocked -- I came to the feeling that I can't handle this. That this is shocking, when they were so wild and like, that their own teacher couldn't get them into discipline anyhow. I thought: 'How can I do it then?' -- And in a situation like that, it was, of course, a bit difficult for me too to start teaching them, if they don't listen even to their own teacher and then there comes a student teacher. And I didn't know that, how to manage that class because I didn't have any experiences beforehand. (Subject student teacher/lack of support/teacher educator)*

Table 6. Student teachers' sense of instrumental support.

| APPROPRIATENESS         | DIRECTION       | CONTEXT   |
|-------------------------|-----------------|---|
| Appropriate (f = 2)     | receive (f = 2) | teacher educator (f = 1)<br>peer student (f = 1)<br>pupil (-) |
|                         | reciprocal (-)  | teacher educator (-)<br>peer student (-)<br>pupil (-)         |
|                         | offer (-)       | teacher educator (-)<br>peer student (-)<br>pupil (-)         |
| Not appropriate (-)     | receive (-)     | teacher educator (-)<br>peer student (-)<br>pupil (-)         |
|                         | reciprocal (-)  | teacher educator (-)<br>peer student (-)<br>pupil (-)         |
|                         | offer (-)       | teacher educator (-)<br>peer student (-)<br>pupil (-)         |
| Lack of support (f = 3) |                 | teacher educator (f = 3)<br>peer student (-)<br>pupil (-)     |

(f) = number of mentions; (-) = not mentioned

Concluding the results of *study I*, informational support was received and expected more from rather formal relationships, such as teacher educators. In turn, emotional support seemed to be more multidimensional in terms of its relationships and sources including peer students, teacher educators and pupils at school. In this study, focus was on the social support system, more detailed types of social support enabled in teacher education as well as its sources and directions. Because it seems that social support enabled in teacher education, or lack of it, build both empowerment and burdening in the student teachers' social support system, it is necessary to examine these paths more profoundly. Further, the next chapter will deal with more detailed strategies student teachers utilise to regulate their study burnout. It does not only expand the examination of social support in terms of seeking and providing support, but it also examines self-regulative strategies student teachers utilise.

## 4.2 STUDENT TEACHERS' PROACTIVE STRATEGIES FOR AVOIDING STUDY-RELATED BURNOUT DURING TEACHER EDUCATION (*STUDY II*)

The aim of the second study was to gain a better understanding of the function of proactive strategies in buffering study burnout among first-year primary school student teachers. In this sub-study, burnout was considered as three distinct but related dimensions, i.e. exhaustion, cynicism and inadequacy. Conversely, proactive strategies were seen as one entity constructed of self- and co-regulative strategies. It

was hypothesised that proactive self- and co-regulative strategies regulate student teachers' cynicism towards studies, the experienced exhaustion in studies and inadequacy in studying. Further, exhaustion in studies and inadequacy in studying regulate cynicism towards studies. Both means and hypothesised latent factor structures were examined to test the hypothesis. The Path model fitted moderately to the data;  $\chi^2(81) = 163.35$ ,  $p < .001$ ; RMSEA = .07 (90% C.I. .05/.08); CFI/TLI = .94/.92; SRMR = .09.

Results showed that student teachers' utilised proactive strategies, self- and co-regulation, buffered effectively risk of study burnout in terms of exhaustion in studies and experienced inadequacy in studying. More specifically, student teachers' adopted proactive strategies in the first year of their teacher studies were at a relatively high level ( $M = 5.31$ ). Also, results showed that they were able to utilise both self-regulative strategies ( $M = 5.23$ ) and co-regulative strategies ( $M = 5.41$ ) to buffering their own study burnout and that of others during studies. This implies that they, for example, were able to manage their workload and delimit studying as well as ask for and provide needed social support. Further, student teachers' experienced inadequacy ( $M = 3.26$ ) and cynicism towards studies ( $M = 2.64$ ) were at a lower level than exhaustion in studies ( $M = 3.92$ ). This implies that exhaustion, the stress dimension of burnout, is more within the realm of student teachers at the beginning of their studies than feelings of inadequacy, i.e. sense of incompetence and insufficiency, or cynicism that refers to alienation from studies in teacher education. In general, high levels of proactive strategy use combined with low levels of exhaustion, inadequacy and cynicism were reported.

Further, as Figure 4 shows, proactive strategies correlated negatively with exhaustion in studies (-.64) and inadequacy in studying (-.63). Further, inadequacy in studies ( $R^2 = .40$ ) and exhaustion ( $R^2 = .41$ ) were significantly explained by proactive strategies. Conversely as was expected, proactive strategies did not directly regulate cynicism towards studies, i.e. those strategies were ineffective at directly buffering student teachers' cynicism towards their studies. Accordingly, relations of the burnout dimensions were examined. This investigation showed that student teachers' experienced exhaustion correlated negatively with cynicism (-.36), i.e. alienation from studies, whereas inadequacy in studies correlated positively (.90). This indicates that experienced inadequacy, such as sense of insufficiency or failing in studies, increased significantly the sense of cynicism. Moreover, experienced inadequacy and exhaustion explained significantly ( $R^2 = .49$ ) the perceived cynicism.

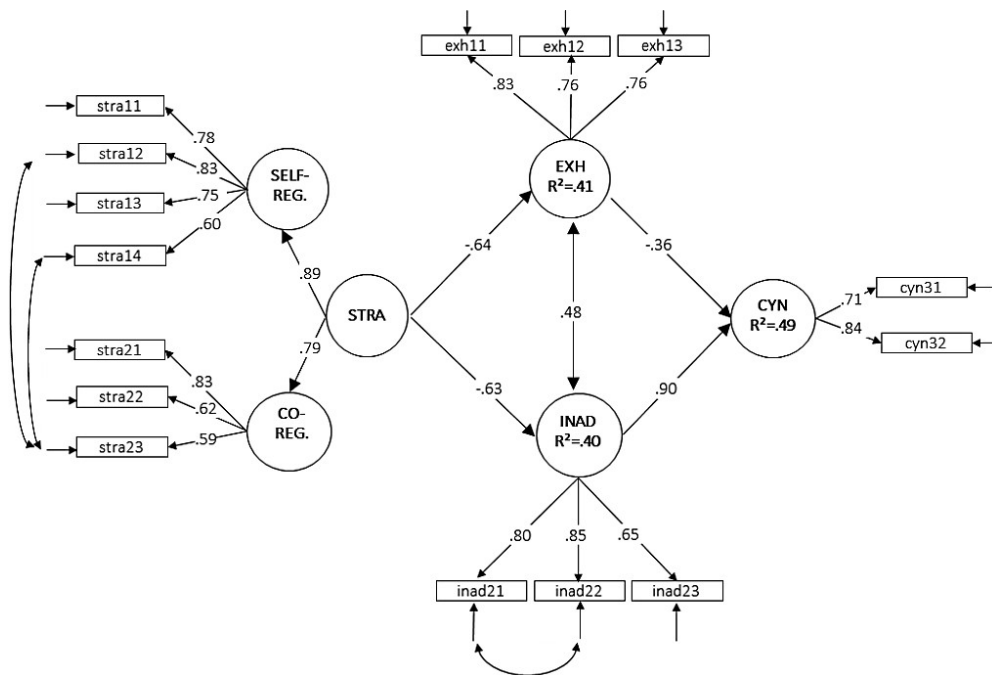

Figure 4. Model of student teachers' proactive strategies to regulate study-related burnout:  $\chi^2(81) = 163.35, p < .001$ ; RMSEA = .07 (90% C.I. .05/.08); CFI/TLI = .94/.92; SRMR = .09.

In this study, proactive strategies for buffering risk of burnout as well as more detailed anatomy of study burnout were examined at one time point in the beginning of teacher studies. In summary, the use of proactive self-regulative and co-regulative strategies buffered sense of exhaustion and inadequacy in studying. Also, experienced inadequacy in studies contributed significantly to the sense of cynicism. After this sub-study, the interrelation between proactive strategies themselves and with the risk of study burnout, as well as individuals' burdening in their teacher education learning environment, was explored in more detail. Also, examination of proactive strategies and study burnout were expanded with a longitudinal setting during the bachelor phase to see how stable these constructs are.

### 4.3 STUDENT TEACHERS' PROACTIVE STRATEGIES AND EXPERIENCED LEARNING ENVIRONMENT FOR REDUCING STUDY-RELATED BURNOUT (STUDY III)

In the third sub-study, interrelations between student teachers' proactive strategies, learning environment and study burnout were examined. These were examined at three time points, once a year. Thus, this study considered the entire bachelor-phase studies of primary school student teachers. Constructs were examined as mean variables. Burnout was considered as one entirety, whereas proactive strategies were considered separately, including self-regulative and co-regulative strategies. It was hypothesised that self-regulative strategy correlates positively with co-regulative



strategy, and both these strategies correlate negatively with experienced study burnout at every time point. Further, co-regulative strategy correlated positively with the perceived leaning environment, which correlates negatively with experienced study burnout. Also, it was hypothesised that these constructs are relatively stable and can be predicted over time. The Path model fitted to the data;  $\chi^2(42) = 54.916, p = .09$ ; RMSEA = .03 (90% C.I. = .00–.06); CFI/TLI = .99/.98; SRMR = .07.

The results showed that student teachers employed proactive strategies for reducing their burnout and for regulating the perceived fit between the learning environment and themselves (see Figure 5). Moreover, they experienced the teacher education learning environment positively in terms of supportive climate, social support from teacher educators, sense of equality and recognition from teacher educators. Experienced burnout symptoms remained at a moderate level during bachelor-phase studies.

Student teachers' reported use of proactive self-regulative strategy was associated positively with the use of co-regulative strategy, i.e. the employment of self-regulation contributed further to the utilisation of co-regulation in each academic year. Results also showed that the use of proactive self-regulative strategy was negatively associated with the experienced study burnout, i.e. it reduced risk of experiencing burnout during the first three years of teacher studies. Conversely as was expected, co-regulative strategy adopted by student teachers did not correlate directly with study burnout. Yet, student teachers' employed co-regulative strategies contributed to learning environment experiences that further reduced experienced study burnout symptoms. Interrelations between proactive self-regulative and co-regulative strategies, perceived fit between learning environment and student teacher and study burnout were somewhat stable in each of the three academic years.

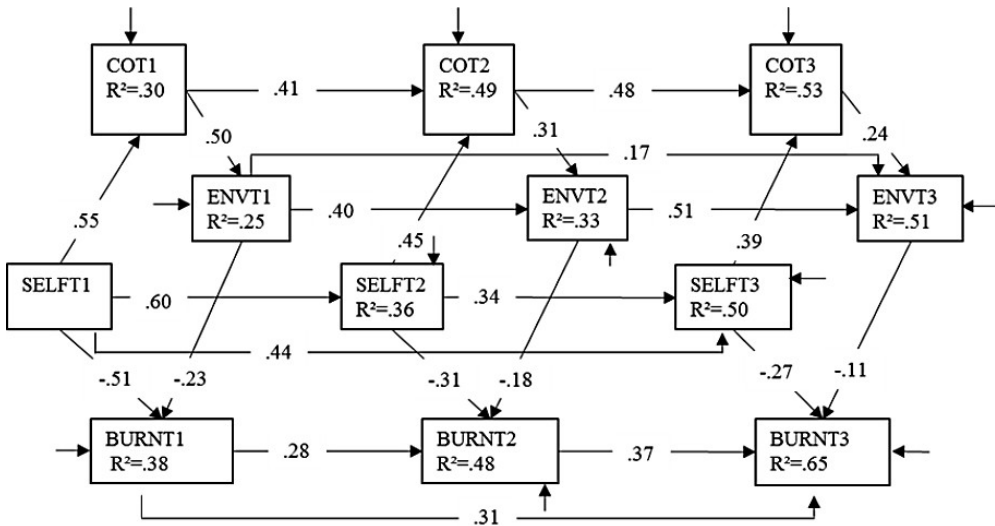

Figure 5. Standardised model:  $\chi^2(42) = 54.916^*, p = .09$ ; RMSEA = .03 (90% C.I. = .00–.06); CFI/TLI = .99/.98; SRMR = .07. \* $\chi^2/df$  ratio = 1.31. All parameters were significant at  $p$  level <.05. Note: One [autocorrelative] residual covariance of the observed factor indicators was added

Further, results indicated that proactive strategies, learning environment and study burnout were stable and could be predicted over time during bachelor studies. It was shown that earlier employment of self-regulative strategy, perceived fit between learning environment and student teacher, as well as experienced study burnout symptoms predicted those of later through the academic years and these constructs were somewhat stable. This was seen, for example, in student teachers' experiences that perceiving equality and recognition in the first year of studies predicted their experience of perceived equality and recognition later on during the bachelor phase of their studies. However, employment of the proactive self-regulative strategy seemed to be more predictable than the use of co-regulative strategy, which was predictable only for the next academic year and not between year one and three.

## 5 DISCUSSION

In this dissertation, the construction and regulation of study well-being during teacher education was examined in three Finnish universities. The student teachers' whole study path was considered in order to build a deeper understanding of study well-being. Survey data covered the students' bachelor-phase studies, whereas interview data comprised students at the final stage of their studies. These students were asked to reflect on their whole study path. In the following, methodological choices and ethical questions are reflected upon, in addition the results are discussed in terms of their scientific importance, and further synthesis is made between three sub-studies (*studies I, II and III*). Also, directions for the future research are addressed.

### 5.1 METHODOLOGICAL REFLECTIONS

#### 5.1.1 General methodological reflections

This study drew on the mixed methods approach (Creswell, 2014; Tashakkori & Teddlie, 2016) by bringing together different data and analysis to gain a deeper understanding of the complexity of study well-being. Further, this study is built upon pragmatism (Creswell, 2014; Creswell & Plano Clark, 2017; Johnson & Onwuegbuzie, 2004; Johnson et al., 2007). Interview data allowed the participants to use their own expression and show their viewpoints while they were reflecting on their own study paths and episodes that were pivotal for them. In turn, surveys made it possible to examine regulation and construction of well-being in studies in the light of utilised proactive strategies and the perceived learning environment, and particularly to examine the stability and predictability of these constructs over time. This was possible due to the vast interview and survey data from the different phases of teacher studies. Further combined findings of the different data provided complementary knowledge that increased the reliability of the conclusions.

Methodological triangulation was utilised to improve the validity and reliability of the study (Patton, 2002). Reliability of the study was increased by investigator triangulation, to reduce potential single-person biases (Cohen et al., 2011; Patton, 2002). This was utilised both in collecting as well as analysing the data. Instruments for collecting the data were designed in collaboration between researchers of the research group through conversation. Also, consensus of the results was found through conversation, which diminishes the possibility of subjective views of a single researcher. This study utilised also time triangulation (Cohen et al., 2011) to enhance the reliability of the study by collecting both cross-sectional and longitudinal data. Quantitative analyses were performed both by one timepoint as well as longitudinally three times. Longitudinal analysis completed and confirmed the results of the cross-sectional study. Qualitative data, in turn, aimed to capture the whole study path. Also, this study used different data and methods (see Cohen et al., 2011; Patton, 2002) as well as different theoretical backgrounds (Cohen et al., 2011) to improve credibility.

Mixed methods research can be assessed by inference quality and inference transferability (Teddlie & Tashakkori, 2003). Inference quality refers to quantitative internal

validity and the qualitative trustworthiness and credibility of interpretation (Gelo et al., 2008; Teddlie & Tashakkori, 2003). Inference transferability refers to external validity (generalisability) and qualitative transferability (Gelo et al., 2008; Teddlie & Tashakkori, 2003), i.e. findings of the study are reflected in the light of the possibility to extrapolate them beyond the conditions prevailed in the particular study (Teddlie & Tashakkori, 2003). Inference quality can be examined in terms of design quality and interpretative rigor (Teddlie & Tashakkori, 2003). Design validity in this dissertation was improved by studying student teachers' study well-being in three complementary studies. *Study I* examined study well-being in terms of empowerment and burdening, whereas *studies II* and *III* examined study well-being in terms of study burnout. Also, social support system and actualised social support was examined in complementary theoretical aspects. More detailed examinations of the findings in different data are presented later.

During the research project, special attention was paid to the data collection, so that situations and instructions were as similar to all participants as possible. Researchers that collected the data were trained to collect it. Additionally, all the analyses, both qualitative and quantitative, were validated in several discussions among the research group. Also, it should be noted that since the data in all studies were self-reports, it may have biases. For example, study participants may have responded to questions in a way that makes them look good, i.e. student teachers may have over-reported behaviour that is seen as appropriate and vice versa (see Donaldson & Grant-Vallone, 2002). Also, participants may have understood the questions or claims differently.

### **5.1.2 Methodological reflections of interview study**

In *study I*, data were collected by interviewing student teachers (Kvale, 2007; Patton, 2002). Before actual interviews, pilot interviews were carried out to validate the interview protocol and the used instrument (see Ahonen et al., 2015). Furthermore, semi-structured interview data were collected to better understand student teachers' perspectives of the social support system during teacher education. Semi-structured data provided rich data to identify and analyse social support enabled in teacher education. The study had sufficient sample size ( $N = 40$ ). The criterion for selection in purposeful sampling was to select participants that may best illuminate the studied phenomenon, i.e. student teachers' social support system and actualised social support in terms of well-being (see Creswell, 2013; Kemper, Stringfield, & Teddlie, 2003). Also, the interview allowed participants to reflect on the whole study path as they were final-stage students.

The retrospective approach applied in the interviews brings with it some challenges, especially in relation to the quality of the data produced (e.g., Cox & Hassard, 2007; Hardt & Rutter, 2004). The participants of this study were interviewed once, and the interview focused on student teachers' study path in teacher education as a whole. However, experiences are situated in time and context, which may be challenging to recall afterwards. On the other hand, experiences that student teachers introduced were likely to be significant for their study path. Visualisation-based interview (e.g., Reavey, 2012) was used to support participants' retrospective recall of their experiences, i.e. interview began with student teachers visualising their own study path and identifying critical episodes. However, those visualisations were not used in analysis, except as researcher's visual assistance, while researcher followed the interviews.

Criteria for operationalising the concept and categorising data in qualitative content analysis were critically discussed and evaluated within the research group. Criteria were discussed at the end of each phase of analysis (see Miles & Huberman, 1994; Yardley, 2008). Also, to improve credibility of the analysis and results, parallel categorisation was used. For example, qualitative data were partially analysed by multiple coders and reliability was enhanced by examining the stability of responses to multiple coders (see Creswell, 2013), i.e. investigator triangulation was utilised (Cohen et al., 2011; Patton, 2002) during the analysing process. In cases of disagreement or uncertainty, reflective discussion was exploited to lead to consensus. Also, there was an aspiration to make the analysis of data transparent (see Yardley, 2008). For example, a figure to describe the phases of analysis was presented. Validity of the analysis and findings was supported by theory that guided the concepts and analysis structure and hence, the analysis, especially in terms of types of social support. Also, verbatim citations were offered to make analysis and inferences transparent (see Yardley, 2008).

The potential limitations of the transferability (e.g., Malterud, 2001) of the results of *study I* should be noted. Qualitative data were collected from one Finnish university. Because the data was collected from one university, it is necessary to be cautious in transferring the results to other teacher educational contexts in Finland or other countries that may have different teacher education systems (see Teddlie & Tashakkori, 2003). Countries differ in their teacher education programmes, hence findings may not be relevant to another teacher education context. However, this dissertation aspired to describe the context of the research, also, to give information about transferability to other teacher education contexts (see Creswell, 2013; Lincoln & Guba, 2000). Also, the *studies II* and *III* that investigated partially the same phenomenon, expanded the examination to three universities. Further, the criteria for participant selection were constituted to enhance representativeness of the informants (Krefting, 1991). In addition, in the interview, direct questions were not asked about social support practices, but descriptions of empowering and burdening social support or lack of social support emerged freely as the interviewees spoke. In this connection, it is necessary to be cautious when interpreting the results of *study I* related to such matters as absence of talk about social support offered or given.

### 5.1.3 Methodological reflections of survey studies

In *studies II* and *III* utilised data were collected with a survey that measured student teachers' proactive strategies and study burnout. Additionally, in *study III*, teacher education learning environment was explored. In line with the aim of this dissertation study, both cross-sectional and longitudinal approaches were utilised. Since cross-sectional research does not allow examination of causality, it is examined in *study III*. This allowed follow-up structures during several time frames and for conclusions to be drawn regarding causality. Also, the proactive strategies have been studied as whole but also separately concerning the relation between self-regulative and co-regulative strategies. Burnout was examined both as one entity and from the viewpoint of the more precise anatomy of it. Furthermore, the use of structural equation modeling (SEM) allowed examination of a set of complex relations between several variables.

The instrument that was modified from the validated Socio-Contextual Teacher Burnout Inventory (Pietarinen et al., 2013b) to student teacher context was pilot tested to ensure its functionality as well as to improve its validity in the teacher education

context. Also, some of the items are based on the previous scales, for example one measuring the stress part of burnout (see Elo et al., 2003) and further, that item was validated in teachers. However, the use of survey instrument requires further evaluation, and the construct validation of the scales is needed, since it has not been tested or validated in other countries outside Finland nor in different teacher education contexts and systems. This needs to be taken into account as a limitation while generalising the results of the *studies II* and *III*. Also, there are limitations in sampling chosen for the studies. Because participants in *studies II* and *III* were chosen with non-probability sampling containing three Finnish universities, the results cannot be generalised to a whole student teacher population without cautions (Cohen et al., 2011; Onwuegbuzie & Leech, 2010). However, the findings of the study that support each other imply that instrument can be used in the Finnish university context.

Participants in *studies II* and *III* were the same student teachers from the same three universities. Accordingly, it is important to note that samples used in the *studies II* and *III* were not independent. Particularly, in *study II* the response rate was high (83 %). However, more detailed analysis showed that response rates between universities varied. Analysis of the data did not indicate that data would have been biased, i.e. there were no significant differences between the three universities concerning study burnout, proactive strategies and learning environment. Also, it is common that there is some loss in respondents while performing survey research, especially during longitudinal research. In *study III* the response rates lowered from 83 % to 55 %, i.e. there were more loss when teacher studies proceeded. However, it remained adequate. Further, loss in participants can be seen as a challenge for longitudinal research and this should be considered, for example, by making sure the sample size is large enough already at the beginning for the multivariable analysis (Leskinen, 2005). Lowering response rates at *study III* from time 1 to time 3 should be taken into account in terms of reliability, for example considering who are those students that were not reached. Also, although the demographic characteristics of each time-point were sufficiently representative of the student population as a whole, it is possible that the behaviour of students who did not repeatedly respond may be different from those who responded. For those who were not able to be reached for a face-to-face data gathering a questionnaire was sent to their home address to reach as many participants as possible and to decrease the loss.

Members of the research group coded the answers from the survey to SPSS software. To ensure better reliability, the possible misinformation codes were scrutinised, for example, by checking abnormal values. Also, in this study, internal consistency of the scales used was evaluated by counting Cronbach's alphas (Bonett & Wright, 2015; Tavakol & Dennick, 2011). According to Nunnally and Bernstein (1994) the closer the Cronbach's alpha is the value 1, the better the variables represent the same phenomenon. At *study II*, the reliability coefficient for the co-regulative strategy scale was on a moderate level ( $\alpha = .66$ ) and further, Cronbach's alphas for self-regulative strategy ( $\alpha = .84$ ), proactive strategy ( $\alpha = .84$ ), exhaustion ( $\alpha = .81$ ), inadequacy ( $\alpha = .77$ ) and cynicism ( $\alpha = .75$ ) were all adequate (see Nunnally & Bernstein, 1994). For *study III*, the reliability coefficient alphas for self-regulative strategy ( $\alpha^{(\text{min-max})} = .81-.85$ ), learning environment ( $\alpha^{(\text{min-max})} = .86-.88$ ) and study-related burnout ( $\alpha^{(\text{min-max})} = .81-.83$ ) scales were adequate in each measurement point. Further, the Cronbach's alphas for the co-regulative strategy ( $\alpha^{(\text{min-max})} = .64-.73$ ) scale were also consistent over time, but at the moderate level (Nunnally & Bernstein, 1994). Since the reliability of the co-regulation part of the scale could have been more optimal, the instrument could be further

developed to accomplish better Cronbach's alpha values. Also, the Cronbach's alpha of co-regulation should be taken into account while generalising the findings.

The fit indices of the tested model in *study II* could have been more optimal, since they did not quite reach the given goodness-of-fit indices values, but were moderate (see Hooper et al., 2008; Hu & Bentler, 1999; Kline, 2015; Muthén & Muthén, 1998–2017; Schreiber et al., 2006). This should be taken into account while interpreting and generalising the findings. However, received model had a theoretical sensibleness, i.e. findings are supported by previous research adequately. On the contrary, fit indices for *study III* indicated a good model fit. Also, *study III* supported the findings of *study II* but gave some novel and complementary knowledge, also.

#### 5.1.4 Research ethics

This dissertation takes into account a good scientific policy, since it is predominance for the acceptability and reliability of the study as well as credibility of the results (see Finnish advisory board on research integrity, 2012). At the beginning, before performing the data collection, permissions to carry out both the interview and survey studies were requested from the heads of the departments of the participating universities. Part of the responsible conduct of research is that participants get sufficient information to support their decision to participate, for example basic information about the research, researchers who carry it out as well as the use of collected data (see Kuula, 2013). To ensure this in this research, informed consents (Cohen et al., 2011; Kvale, 2007; Patton, 2002) were given. The purpose and aim of the study as well as the use and preservation of data were reported to participants. When providing this beginning information, the confidentiality and anonymity of the participants were highlighted (see Cohen et al., 2011; Kvale, 2007). Contact information of the research leaders were given to participants for potential contact. It was told that participation was on voluntary basis and the participants were given an opportunity to withdraw from the study at any phase during the research process if they wanted (see Kvale, 2007; Raffe, Bundell, & Bibby, 2005). Regarding *study III*, longitudinal approach, participants were allowed to make a decision to participate in every questionnaire, one by one. Even if the data were collected during study module face to face, the participation did not affect accomplishment of the course in any way.

By following the principles of privacy and data protection, the possible disadvantage for the participants of the studies were minimised (see Finnish advisory board on research integrity, 2012). In this study, surveys are stored in a locked cabinet in a locked room to make sure that they cannot end up with outsiders. Likewise, the qualitative interview text-files together with pictures about study path are kept locked. Electronic data, i.e. coded surveys, interview tapes and interview text-files are shifted locally. Coding the data and transcription of the recordings are made by members of the research group, and hence, the data have not ended up in the hands of a third party.

Also, the information about the participants is given without compromising their anonymity. Individual participants are not to be able to be identified from published articles or summary (e.g., Barrett, 2000). In quantitative studies (*II* and *III*) results are presented as statistical, whereas in a qualitative study (*I*) the data citations do not include the names of participants but the codes instead.

## 5.2 THEORETICAL REFLECTIONS AND THE SYNTHESIS OF THE FINDINGS

Literature on teacher well-being is extensive, yet the focus has been primarily on in-service teachers, whereas student teachers' study well-being has not been studied to the same extent. This study provides new insights into the determinants and development of student teachers' study well-being, especially how it is constructed in a teacher education learning environment and regulated by the utilisation of proactive self-regulative and co-regulative strategies. Previous studies have suggested that even though beginning teachers have increased risk of suffering from burnout (Brewer & Shapard, 2004; Gavish & Friedman, 2010; Goddard & Goddard, 2006) the majority of them only experience low levels of burnout, which implies that they are both well equipped to cope with the transition to the teaching profession (Hultell et al., 2013), and that their working environment provides them with resources that protect them from developing such symptoms (Sharplin et al., 2010; Shen, 2009). Further, teachers who start to develop burnout symptoms soon after entering into their working life, may have started to experience these symptoms already during their teacher studies (Gavish & Friedman, 2010; Goddard et al., 2006). This implies that student teachers need to learn strategies not only to cope with stressors but also how to enhance their study well-being and that of others intentionally during their studies, and that the learning environment supports both student teachers' study well-being and learning in teacher studies.

The results of this dissertation contribute the growing body of work examining the risk of burnout among student teachers (e.g., see Chan, 2003; Fives et al., 2007) by showing that student teachers faced burdening experiences that may expose them to stress. Such situations were characterised by the mismatch between the demands in studies and enabled resources both in their learning environment (see Hakanen et al., 2006; Peeters & Rutte, 2005) and personal resources, and hindered their meaningful learning increasing risk for developing burnout (see Freudenberger, 1974; Kokkinos, 2007; Maslach, 2003; Maslach et al., 2001). Results of this dissertation suggested that while exhaustion was negatively related to cynicisms, the inadequacy in studying was related to increased levels of cynicism. This implied that inadequacy is a central determinant of cynicism towards studies among student teachers. Also, student teachers experienced inadequacy rather than cynicism in their studies. Beginning teachers, also, have been shown to experience low levels of cynicism while experiencing relatively high levels of inadequacy, which indicates that teaching induces feelings of professional incompetence for some of them (Gavish & Friedman, 2010). Further, there is evidence that distressful events may cause student teachers' feelings of inadequacy (Lindqvist et al., 2017). Sense of inadequacy was caused typically by the mismatch between the feedback received, for instance, from a teacher educator, and student teacher's appraisals of their actions and success in teaching, resulting in reduced feeling of teaching competence. In some occasions, negatively experienced feedback even caused questioning of career choice. Typically, the situations both hindered professional growth, i.e. learning to be a teacher, and reduced student teacher's experiences of study well-being (see also Deci & Ryan, 2000; Ryff, 1995). However, it has been detected that student teachers' sense of inadequacy decrease while their teaching skills increase (Fives et al., 2007).

Further, the results indicated that the relation of exhaustion to cynicism was negative among student teachers, which implied that experienced exhaustion did not



increase student teachers' cynicism. A reason for this may be that students' functional strategies inhibit exhaustion from turning into cynicism. Also, there is some evidence that while facing stressors highly engaged students may suffer from exhaustion, which does not increase their risk for experiencing cynicism due to their commitment (see Maslach & Leiter, 2008; Schaufeli et al., 2002). Accordingly, due to their high commitment, student teachers are not likely to be prone to experiencing cynicism towards their studies in a high amount.

Since teacher education is highly socially embedded, student teachers can learn how to utilise social support that helps them through challenging times or hinders the impacts of stressors emerging during studies in their learning environment. The results showed that teacher education provided a social support system, including both formal and informal support practices, that constructed student teachers' experiences of study well-being. In this system, social support resources and actual use of social support were constructed and enabled. Further, study well-being was contributed by different sources of support, i.e. peer students, teacher educators and pupils. Particularly teacher educators, i.e. formal experts, were found to play a central role in student teachers' experienced study well-being in terms of informational support, which is in line with previous findings (see Helgeson, 2003). Emotional support was primarily embedded in less formal, reciprocal peer interactions. It was also characterised by multiple channels in terms of its sources. However, it typically calls for close relationships to be actualised. The ability to utilise social support resources available in student teachers' learning environment called for initiatives to identify this.

In order to solve the challenges faced in studies, student teachers needed different types of support. Student teachers identified the significance of informational, emotional and instrumental social support for their empowerment (or burdening) in the teacher education learning environment. Particularly, informational support was looked for in order to learn professional skills and knowledge in teacher studies. This finding is supported by a suggestion that informational support enables coping with and solving problems that emerge in the environment (House, 1981; Thoits, 2011). Emotional support provided significant opportunities for sharing, for example feelings and thoughts due to challenging situation that emerged during studies. However, received support had to match the support needed, i.e. to be appropriate. Accordingly, social support contributed to student teachers' empowerment, if received support was both appropriate and matched the demands the learning environment had produced (see also Cohen & Syme, 1985; Wolff et al., 2013). Non-appropriate support or experienced lack of support induced feelings of burdening (see also Tang, 2003), while student teachers experienced mismatch between support needed and that which was provided for them. This implied that there had to be a fit between support received and needed to provide meaningful experiences of the social support system and to support student teachers' study well-being (see Pyhältö, 2018), which was especially detected in student teacher–teacher educator interactions. Furthermore, results partly confirmed previous research showing that student teachers want more support from teacher educators to cope with problems faced in studies (Timošćuk & Ugaste, 2012).

It has been suggested that student teachers adopt and utilise different strategies to cope with academic and professional stressors faced during their teacher studies (e.g., Carnicer & Calderón, 2014). This study contributed to the knowledge on study well-being by showing that student teachers utilised proactive self-regulative and co-regulative strategies to regulate their study well-being. Results suggested that these strategies buffered effectively risk of experiencing symptoms of study burnout during

teacher education. Especially student teachers' utilised proactive self-regulation, i.e. strategies for time and study management (see Randi et al., 2011), to buffer study stressors in advance reduced the risk of experiencing and developing study burnout and was hence particularly functional in regulating one's own study well-being. This was in line with previous research suggesting that teachers' adopted proactive coping is effective in preventing burnout (e.g., Pietarinen et al., 2013a). Further, the proactive strategies that student teachers utilised to regulate their study well-being were related to reduced risk of study burnout primarily in terms of experienced exhaustion and inadequacy in studying (see also Greenglass, 2005; Renk & Smith, 2007). This implied that student teachers were able to support their feeling of competence to study and teach (see Schaufeli et al., 2002) and to block the feeling of exhaustion due to study demands (Leiter & Maslach, 2016; Salmela-Aro & Kunttu, 2010) by utilising proactive strategies. Student teachers may, for instance, set study goals and standards to a more realistic and proper level (Zhang et al., 2007). On the other hand, they may utilise active problem-solving strategies to control possible difficulties in student teacher-learning environment relationships and to remove sources of stress (Folkman, 1984; Kyriacou, 2001).

The results expanded the previous knowledge on proactive self-regulative and co-regulative strategies. Firstly, the results suggested that these different strategies are related (see also Alarcon et al., 2011; Boekaerts & Corno, 2005; Ford & Blaustein, 2013). Self-regulative strategies seemed to support the use of co-regulative strategies, indicating that development of proactive strategies is launched by self-regulation that facilitates development of co-regulation. This implied that being able to regulate one's own well-being proactively supported the identification of the need for co-regulation (see also Newman, 2002), i.e. help-seeking and strategies to support peer students. Hence, the study provided new insights into the relations and development of these strategies during teacher education. However, it may be argued that being able to identify the need for support is not enough, but student teachers need also to have courage and willingness to ask for support. This calls for a learning environment that supports initiatives for seeking help. Further, student teachers were not only receiving social support, but they also actively and reciprocally used and utilised various social support resources enabled in their learning environment by asking for support when needed and being able to support peer students, i.e. they utilised co-regulation. This implied that support dynamics in their learning environment were vast and multidimensional. There is evidence that student teachers have protective qualities, such as social competence (McCallum & Price, 2010) and that they form a social support resource and elicited needed social support practices. This may imply that with proactive strategies, student teachers sufficiently constructed their fit to the social support system where social support resource could form to be better available (see also Aspinwall, 2011; Schwarzer & Knoll, 2003) while constructing their well-being. Also, previous studies have shown that students do purchase resources, such as social support, actively (Gan et al., 2007), and that student teachers recognise the value of building reciprocal relationships with others (Price & McCallum, 2015).

Results also showed that the utilisation of social support resource and co-regulation to solve problems and challenges in studies enhanced the optimal experiences of student teachers' learning environment. While a student teacher has a sense of mastery in their own learning environment (see Ryff, 1995), including building and maintaining a social support system, it is likely to enhance the regulation of study well-being in terms of asking for, offering and receiving support (i.e. reciprocally applying support practices),

as well as taking ownership of their own well-being. Student teachers' utilised co-regulative strategies contributed to the perceived learning environment fit. The result supports previous findings on in-service teachers suggesting that teacher–working environment fit can be enhanced by adopted co-regulative strategies (Pietarinen et al., 2013a). Student teachers' active use of co-regulative strategies contributed and modified their reasonable learning environment experience and the fit between a student teacher and the learning environment. This implies that student teachers may actively use proactive strategies to construct their teacher education learning environment. Experienced fit between a student teacher and his or her learning environment was supported not only by a good atmosphere in teacher education but also support from teacher educators and senses of equality and recognition (see Gavish & Friedman, 2010; Maslach & Leiter, 2008). The result illustrates the importance of the teacher education learning environment to student teachers' studies. Further, there is evidence that student teachers' learning during teaching practice may depend on the socio-emotional atmosphere that is supported by supervisor teacher (Anttila et al., 2016; Hascher et al., 2004). Support from teacher educators is also shown to provide an encouraging and psychologically safe learning environment for student teachers (Tang, 2003) and, hence, triggers for student teachers' learning (Rajuan et al., 2008a). This implied that a supportive learning environment with an encouraging atmosphere and support from teacher educators were significant for student teachers' meaningful learning experiences to become a teacher.

Further, the quality of the learning environment provided by teacher education was a central determinant for student teachers' study well-being. Student teachers' study well-being is constructed in the continuous interaction and dynamics between the individual student teacher and his or her environment (see Maslach, 2003; Maslach & Leiter, 2008). Accordingly, a functional and supportive, positively perceived learning environment reduced the risk of experiencing study burnout, i.e. the fit between student teachers and learning environment constructed their study well-being. This has been previously only detected among in-service teachers (Gavish & Friedman, 2010; Lam & Yan, 2011; Pyhältö et al., 2011). Accordingly, by strengthening the fit between a student teacher and his or her learning environment, student teachers' well-being is enhanced significantly. This calls for intentional and active building and modifying of the learning environment.

Further, it can be argued that both the key determinants for reducing risk of study burnout, i.e. proactive strategies and teacher education learning environment, and the study burnout itself were relatively stable during bachelor-phase studies. This implied that student teachers were able to construct and regulate their study well-being from the beginning of their studies in a sufficient way. Moreover, the results implied that student teachers can actively modify their learning environment by directing and re-directing their own and others' development and behaviour in a way that promotes positive learning environment dynamics and reduces burnout (Fernet et al., 2012; Pietarinen et al., 2013a; Soini et al., 2015). They may, for example, actively and intentionally build a social support system that enables available social support resources and utilises proactive strategies to regulate not only their own study well-being but also supports that of others. This implies that different strategies to regulate study well-being, to create social support resources with those strategies and to build and modify actively the kind of learning environment in which regulation of study well-being is supported, should and can be learnt during teacher education. Also, ability to modify the learning environment and to utilise different proactive strategies may be seen as building blocks to teachers' work after entering into a teacher-career.

### 5.3 EDUCATIONAL IMPLICATIONS

The results of the dissertation study suggested that student teachers' study well-being could be constructed and regulated by a dynamic interplay between the student teacher and learning environment and strategies utilised by student teachers. Accordingly, the results indicated that student teachers should build intentionally and actively their well-being. Furthermore, there is evidence that student teachers with a sense of study well-being are flexible and efficient in solving problems faced during their studies (Hascher et al., 2004). They are committed to academic goals and have control of their own studies (Salami, 2010), which supports their learning to become teachers. While a student teacher experiences study well-being and constructs and regulates it effectively, this has significance to performing studies and gaining meaningful learning experiences that support both professional development and well-being. Furthermore, this study provided some insights into the development of teacher education practices in terms of supporting student teachers' study well-being, and further contributing to their high-quality learning and future professional lives as teachers.

Firstly, the results pointed out the importance of a social support system provided by teacher education. There should be a balance between demands that arise in the teacher education learning environment and resources available in the form of social support (see also Hakanen et al., 2006; Peeters & Rutte, 2005; Sharplin et al., 2010). There is evidence that student teachers face demands and stressors that are centrally related to teachers' profession as well as burdening factors related generally to university studies (Chaplain, 2008; Klassen & Durksen, 2014; Knight et al., 2010; Paquette & Rieg, 2016; Zhang et al., 2007). Also, results implied that teacher education induced to some extent the experiences of inadequacy and exhaustion, i.e. symptoms of study burnout. Hence, there is a need for building and modifying the kind of social support system where sufficient social support resources are available for student teachers and further enables actualised social support. In general, teacher education could create situations where social support resources are identified and further developed.

Also, it was shown that, to be appropriate, social support received had to match the need for support. This calls for intentional identification and evaluation of appropriate social support practices that fit into dynamics between support needed and received. However, results indicated that student teachers experienced mismatch between support needed and received, i.e. there were non-appropriate support and lack of support, especially from the source of teacher educators. There is also previous evidence indicating that teacher educators are not always seen as sufficient sources of emotional support (Chaplain, 2008; Kaldi, 2009) and student teachers call for closer relationships with them to elicit needed support (Timošćuk & Ugaste, 2010, 2012). Accordingly, this study suggested the importance of social support, especially in terms of teacher educators' support, for student teachers' study well-being and meaningful learning experiences. Results suggested that student teachers receive social support, especially emotional support, from their peers, also. This is facilitated by close relationships with others in their learning environment and calls for actively building stable and reciprocal relationships among students (see House, 1981; Pyh lt , 2018). Hence, student teachers should learn to build the kind of social support system where reciprocal emotional support, among other types of support, is enabled. It would require that the appropriate formal and especially informal social support practices are intentionally developed as a resource for academic and professional learning, which calls for teacher education to facilitate collaborative practices, for example,

of analysing study well-being. This means reflecting together on the types of social support as well as how the sources of support, need for support, and appropriateness of a certain type of support vary in different contexts, i.e. the fit of support practices. Furthermore, multifaceted social support, for example from more capable others, is needed to support learning in the emotionally safe and cognitively relevant learning environment favourable for learning new skills and knowledge to become a teacher (see also Hadwin & Oshige, 2011), especially in challenging situations.

Secondly, the results indicated that in order to improve study well-being, it is necessary to promote the use of appropriate coping strategies from the beginning of studies (see also Carnicer & Calderón, 2014). Especially, the importance of adaptation and utilisation of proactive strategies to regulate study well-being during teacher education was shown. This is detected among in-service teachers, also (see Pietarinen et al., 2013a). Even if the results of this study indicated that student teachers utilise self-regulative and co-regulative strategies functionally, previous studies have pointed out that some first-year student teachers have unhealthy coping strategies and experience exhaustion (Reichl et al., 2014). Hence, this sets a challenge for teacher education to support the intentional development and learning of a variety of effective and active strategies, with which to support well-being during studies. Since the results implied that experiences of inadequacy occurred in studies and that it provided a route to cynicism, it can be argued that particularly efforts to buffer student teachers' sense of inadequacy might be worthwhile. Also, there is evidence that beginning teachers' sense of inadequacy is high (Gavish & Friedman, 2010). This calls for adopting effective strategies to buffer particularly inadequacy already during teacher education. Cynicism, further, may be problematic because it may alienate student teachers from meaningful learning to become teachers. Further, teacher education should facilitate equipping student teachers with proactive strategies that can be transferred across different contexts (see Price & McCallum, 2015) and can further be shifted to working life.

Challenges faced during studies and in the teacher profession call for skills to cope in advance. It has been argued that the use of proactive strategies is characterised by its future-oriented nature (Aspinwall & Taylor, 1997; Gan et al., 2007; Greenglass, 2005; Straud et al., 2015). It may be suggested that since proactive coping is aimed to hinder future difficulties, it would be significant to reflect and develop those means that enable buffering of burdening in advance to be used in the teacher career. I.e. student teachers should be skilled in strategies during teacher education that can be utilised at the beginning of their teaching career, also, which means developing strategies to solve problems in a flexible way and to see them as challenges (see Greenglass & Fiksenbaum, 2009; Schwarzer & Taubert, 2002). Further, skills to regulate well-being may be seen as a part of becoming a competent teacher. Accordingly, to prevent the risk of developing burnout should be seen not as separate stress coping methods, but as a part of the entirety of studies and learning, and hence those need to be explicitly integrated into teacher education practices. Being capable of actively buffer risk of burnout in a teaching career is facilitated by developing an understanding of the dynamic relations between teachers' professional well-being and proactive strategies to regulate it already during teacher education. Hence, this calls for learning both self-regulative and co-regulative proactive strategies to be facilitated from the beginning of teacher studies. This includes, for example, learning how actively manage time (e.g., Misra & McKean, 2000; Paquette & Rieg, 2016) and to contribute to and utilise social resources (e.g., Renk & Smith, 2007), such as building social networks.

Results showed that student teachers are able to seek help from their peers as well as give support to others reciprocally. Since proactive coping includes gathering social resources (Aspinwall, 2011) and developing required skills to utilise those resources (Schwarzer & Taubert, 2002), teacher education can be seen as a place to become trained in these. It may call for the need to develop actively student teachers' social skills and qualities, such as social competence (McCallum & Price, 2010) to be better able to construct protective structures in the form of collegial support, such as seeking help from peers (see Sharplin et al., 2010; Shen, 2009) intentionally. Teachers who experience high social support are shown to use active, problem-focused coping (Shen, 2009). This calls for teacher education to facilitate guiding students to build social support resource along with the use of active strategies, especially problem-focused strategies, that encourage them to define and create alternative solutions to a faced problem itself (see Chang, 2013; Lazarus & Folkman, 1984) and are addressed to the learning environment and difficulties in the student teacher–environment relationship (see Folkman, 1984). Also, for example, teaching practice may generate situations when student teachers have an opportunity to follow more experienced colleagues in different challenging classroom situations as they model strategies to handle the situations effectively, since evidently, according to Howard and Johnson (2004), in-service teachers can learn and develop coping strategies by reflecting on and following more-advanced peers within their teacher community.

Thirdly, the results of the dissertation showed the importance of learning environment for student teachers' experiences of study well-being. This learning environment was especially built in a social transaction together with peer students and teacher educators. Results, for example, indicated that student teachers' well-being developed in the dynamic interplay between the individual student teachers and their learning environment (see also Maslach, 2003; Maslach & Leiter, 2008). Further, the results indicated that by paying attention to the fit between a student teacher and his or her learning environment, study well-being can be enhanced. This challenges student teachers to be capable of being active in constructing and modifying this fit. This means, for example, building an encouraging atmosphere in teacher education, which further supports the construction of psychologically safe learning environment for student teachers' learning to become a teacher. Building a supportive learning environment and social support system within it should be a solid part of teacher education, so that a supportive kind of acting culture could be adopted in teacher work, also. In this culture student teachers, or future working teachers, have a sense of equality and mutual respect or recognition from teacher educators or colleagues, which supports their well-being (see also Gavish & Friedman, 2010; Maslach & Leiter, 2008; Maslach et al., 2001). However, it has been shown that even if student teachers expect to have respect from their supervisor teacher (Timošćuk & Ugaste, 2012), mutual respect from them during teaching practice is reported to lack (Timošćuk & Ugaste, 2010).

Student teachers' sense of being able to influence their own learning environment can be supported. Environmental mastery refers to student teachers' sense of being able to competently manage their own learning environment and to use effectively surrounding opportunities, such as social support resources in their learning environment (Ryff, 1995). It can be argued that environmental mastery is an important component of student teachers' well-being (see Ryff, 1995). Further, student teachers may make subjective evaluations of feelings of this mastery (Diener et al., 1998). This calls for student teachers to actively modify their learning environment by directing their own and others' development and behaviour in a way that enhances positive

learning environment dynamics and reduces a risk of burnout (see Fernet et al., 2012; Pietarinen et al., 2013a; Soini et al., 2015). This ability is also needed in future work as teachers. However, this requires learnt and intentionally developed skills, such as skills to utilise co-regulative strategy, which is crucial for modifying and constructing the learning environment with peers as well as the fit between a student teacher and learning environment in a meaningful way.

Finally, at its best student teachers learn to construct and regulate actively their well-being during their studies in a way that supports their effective functioning as teachers. Hence, student teachers benefit from understanding the development and function of effective strategies and supportive environments for their study well-being, as well as work well-being in the future. It may be proposed that ways to cope with stress during teacher education are also meaningful in later working life (see Sääntti, 1999). Hence, researching student teacher and teacher well-being and reflecting on appropriate ways to promote it has its importance. Therefore, facilitating student teachers' capacity to construct and regulate their work well-being and that of others intentionally and consciously should actively promote the transition to work life and integration with a school's social support system. For example, if they learn to recognise the significance of and utilise social resources and collegial support during their teacher studies, they are more likely to rely and actively draw on them when entering work as teacher. This reduces the risk for developing burnout at the beginning of a teacher career that has shown to be challenging and stressful (see Chan, 2003; Goddard & Goddard, 2006; Tynjälä & Heikkinen, 2011). Further, facilitating a safe learning environment and learning communities during teacher education, that may have a meaning in building and developing well-being in their future work as a teacher, has its importance in teacher education. Concluding, being able to actively buffer teacher burnout already from the beginning of teaching, teachers should have developed an understanding of the dynamic relations between well-being, learning and working environment and the use of functional proactive strategies to enhance their well-being before entering the teaching profession.

While a student teacher learns to regulate and construct well-being already during their studies, it may have significance in enhancing their own well-being in future work as a teacher, and further as a supporter of pupils' well-being (see also Yager, 2009). Furthermore, teachers' well-being may promote (Roffey, 2012) or challenge (Lambert, McCarthy, O'Donnell, & Wang, 2009) pupils' well-being. Understanding the prevention of teachers' occupational stress and burnout on a deeper level is relevant in a practical point of view, since at its best teachers' well-being has importance to both pupils' and teachers' learning. Hence, constructing supportive learning environments with social support resources formulated in teacher education, as well as identifying and reflecting strategies student teachers already utilise and adopt during their studies, has its importance to facilitate to better meet the challenges at teachers' and pupils' well-being.

## **5.4 FUTURE RESEARCH**

This study will address and answer, in its own part, the challenge to understanding and mapping teacher well-being by researching forthcoming teachers' study phases with cross-sectional and longitudinal research during teacher education, wherein the basis for the teacher profession is built and formulated. However, there are questions that need further elaboration and those that remain unanswered.

In future research, it would be beneficial to explore received quantitative (*studies II and III*) results in greater detail including a qualitative approach, for example by conducting interviews to deepen the gained knowledge. These interviews could include viewpoints about experienced study well-being as well as strategies that student teachers use, i.e. to deepen the previous understanding and to confirm novel results about the significance of self-regulative and co-regulative strategies in student teachers' well-being. Also, the understanding of learning environment and the learning environment fit, as well as its meaning related to study well-being and construction of protective structures, could be broadened.

On the other hand, the interviews could contain questions about the student teachers' thoughts about their future work as teachers in terms of well-being, for example, the meaning of social support in teachers' future work or the construction of the working environment that supports work well-being. Student teachers' thoughts about factors related to teacher well-being and ideas about how to enhance one's own work well-being could be mapped. Student teachers could reflect if their teacher studies prepared them to regulate their own well-being while they transfer to a teaching career, and more specifically, whether these skills were learnt during teacher education intentionally and by being active in the student community. These reflections, especially concerning the beginning of a teacher career, that has been found to be challenging (see Goddard & Goddard, 2006; Goddard et al., 2006; McCallum & Price, 2010), could provide significant knowledge for teacher education.

Furthermore, novel findings of the anatomy and the path of study burnout dimensions in teacher education need to be examined more closely. Also, the variable-centred results of the performed quantitative studies (*II and III*) indicated that proactive strategies regulate study burnout in its entirety and the separated dimension of it. However, it would be important to utilise a more person-oriented approach to analyse and identify what kind of profiles can be found regarding burnout symptoms and the use of strategies, and further, to gain a more in-depth understanding about different student teacher profile groups. Or in more detail, it would be beneficial to understand different dimensions of burnout and the stage of utilised strategies, i.e., for example, what kind of strategies students who suffer from feelings of inadequacy utilise to regulate their well-being. These student groups detected by quantitative analysis could be further studied by utilising the qualitative interview data, also.

One possibility is to follow, both qualitatively and quantitatively, those students who participated in *study II and III*, as they have entered the workforce as teachers and it would be possible to research the beginning teachers' utilisation of proactive strategies and the meaning of the working community. It would be interesting to study if these beginning teachers sense that experiences of regulating their own well-being during teacher education have been helpful as they started their teaching-career. This is because it has been suggested that how students have learned to deal with stress may proceed to working life after graduation (see Sääntti, 1999). Longitudinal research with the same student teachers utilised in this dissertation could be extended to their teacher career, especially while the results implied that the use of strategies was somewhat stable overall and hence it may be that low utilisation of effective strategies proceeds in working life as well. On the other hand, because previous research has argued that beginning teachers suffer from a sense of inadequacy rather than cynicism (Gavish & Friedman, 2010), it could be interesting to investigate how this trend is realised in the Finnish teacher population and how strategies utilised and learnt during teacher education buffer sense of inadequacy. This would also be of specific interest



because this dissertation study suggested the route from inadequacy to cynicism that, according to previous research, can be seen as a distant attitude towards work and other people (Bresó et al., 2007; Maslach, 2003; Maslach et al., 2001; Schaufeli et al., 2002), for instance pupils.

In this dissertation, the teacher educators' role in construction of student teachers' study well-being has been a minor part of research by examining the enabling of social support as well as construction of the perceived teacher education learning environment. In the future, it would be important to focus more on the role of teacher educators in facilitating the student teachers' learning of modifying intentionally the learning environment and strategies alongside with student teachers themselves. Another area of study could be how the relationship between teacher educators and student teachers constructs the experience of the teacher education learning environment and learning environment fit as well as experienced study well-being. For example, the findings of the study detected teacher educators' significant role in giving feedback that supports meaningful learning processes in the teacher profession or supporting the use of active and effective strategies. Also, an efficient way to educate well-being future teachers may be by teaching them not only the content but different ways to study and regulate well-being at the same time.

# REFERENCES

- Ahonen, E., Pyhältö, K., Pietarinen, J., & Soini, T. (2015). Student teachers' key learning experiences—Mapping the steps for becoming a professional teacher. *International Journal of Higher Education*, 4(1), 151. doi: 10.5430/ijhe.v4i1p151
- Alarcon, G. M., Edwards, J. M., & Menke, L. E. (2011). Student burnout and engagement: A test of the Conservation of resources theory. *The Journal of Psychology: Interdisciplinary and Applied*, 145(3), 211–227. doi: 10.1080/00223980.2011.555432
- Anttila, H., Pyhältö, K., Soini, T., & Pietarinen, J. (2016). How does it feel to become a teacher? Emotions in teacher education. *Social Psychology of Education*, 19(3), 451–473. doi: 10.1007/s11218-016.9335.0
- Aspinwall, L. G. (2011). Future-oriented thinking, proactive coping, and the management of potential threats to health and well-being. In S. Folkman (Ed.), *The Oxford handbook of stress, health and coping* (pp. 334–365). Oxford, New York: Oxford University Press. Retrieved from [https://books.google.fi/books?hl=fi&lr=&id=z1HG15HeqNQC&oi=fnd&pg=PA334&dq=aspinwall+coping&ots=n8q6LG\\_sLw&sig=aRHHoNLqReqT4W0WBIRr0Ns7gU&redir\\_esc=y#v=onepage&q=aspinwall%20coping&f=false](https://books.google.fi/books?hl=fi&lr=&id=z1HG15HeqNQC&oi=fnd&pg=PA334&dq=aspinwall+coping&ots=n8q6LG_sLw&sig=aRHHoNLqReqT4W0WBIRr0Ns7gU&redir_esc=y#v=onepage&q=aspinwall%20coping&f=false). May 8<sup>th</sup>, 2018.
- Aspinwall, L. G., & Taylor, S. E. (1997). A stitch in time: Self-regulation and proactive coping. *Psychological Bulletin*, 121(3), 417–436. doi: 10.1037/0033-2909.121.3.417
- Barrera, M. Jr., & Ainlay, S. (1983). The structure of social support: A conceptual and empirical analysis. *Journal of Community Psychology*, 11(2), 133–143. doi: 10.1002/1520-6629(198304)11:2<133::AID-JCOP2290110207>3.0.CO;2-L
- Barrett, M. (2000). Practical and ethical issues in planning research. In G. M. Breakwell, S. Hammond, & C. Fife-Schaw (Eds.), *Research methods in psychology* (2<sup>nd</sup> ed.) (pp. 22–40). London: SAGE Publications.
- Bengtsson, M. (2016). How to plan and perform a qualitative study using content analysis. *NursingPlus Open*, 2, 8–14. doi: 10.1016/j.npls.2016.01.001
- Bermejo-Toro, L., Prieto-Ursúa, M., & Hernández, V. (2016). Towards a model of teacher well-being: Personal and job resources involved in teacher burnout and engagement. *Educational Psychology*, 36(3), 481–501. doi: 10.1080/01443410.2015.1005006
- Bewick, B., Koutsopoulou, G., Miles, J., Slaa, E., & Barkham, M. (2010). Changes in undergraduate students' psychological well-being as they progress through university. *Studies in Higher Education*, 35(6), 633–645. doi: 10.1080/03075070903216643
- Boekaerts, M., & Corno, L. (2005). Self-regulation in the classroom: A perspective on assessment and intervention. *Applied Psychology: An International Review*, 54(2), 199–231. doi: 10.1111/j.1464-0597.2005.00250.x
- Boekaerts, M., Pintrich, P., & Zeidner, M. (2005). *Handbook of self-regulation*. USA: Elsevier.
- Bonett, D. G., & Wright, T. A. (2015). Cronbach's alpha reliability: Interval estimation, hypothesis testing, and sample size planning. *Journal of Organizational Behavior*, 36(1), 3–15. doi: 10.1002/job.1960
- Bowen, N. K., & Guo, S. (2011). *Structural equation modeling*. Oxford University Press. Retrieved from [https://books.google.fi/books?hl=fi&lr=&id=VN9oAgAAQBAJ&oi=fnd&pg=PP1&dq=structural+equation+modeling&ots=bdefhwrtD&sig=\\_8BE9oP3WIZrbJna1CAS9yV42Y&redir\\_esc=y#v=onepage&q=structural%20equation%20modeling&f=false](https://books.google.fi/books?hl=fi&lr=&id=VN9oAgAAQBAJ&oi=fnd&pg=PP1&dq=structural+equation+modeling&ots=bdefhwrtD&sig=_8BE9oP3WIZrbJna1CAS9yV42Y&redir_esc=y#v=onepage&q=structural%20equation%20modeling&f=false). February 3<sup>rd</sup>, 2017.
- Brackett, M. A., Palomera, R., Mojsa-Kaja, J., Reyes, M. R., & Salovey, P. (2010). Emotion-regulation ability, burnout, and job satisfaction among British secondary-school teachers. *Psychology in the Schools*, 47(4), 406–417. doi: 10.1002/pits.20478
- Brannan, D., Biswas-Diener, R., Mohr, C. D., Mortazavi, S., & Stein, N. (2013). Friends and family: A cross-cultural investigation of social support and subjective well-being among college students. *The Journal of Positive Psychology*, 8(1), 65–75. doi: 10.1080/17439760.2012.743573
- Braun, V., & Clark, V. (2006). Using thematic analysis in psychology. *Qualitative Research in Psychology*, 3(2), 77–101. doi: 10.1191/1478088706qp063oa
- Bresó, E., Salanova, M., & Schaufeli, W. B. (2007). In search of “third dimension” of burnout: Efficacy or inefficacy? *Applied Psychology: An International Review*, 56(3), 460–478. doi: 10.1111/j.1464-0597.2007.00290.x
- Brewer, E. W., & Shapard, L. (2004). Employee burnout: A meta-analysis of the relationship between age or years of experience. *Human Resource Development Review*, 3(2), 102–123. doi: 10.1177/1534484304263335
- Caires, S., Almeida, L., & Vieira, D. (2012). Becoming a teacher: Student teachers' experiences and perceptions about teaching practice. *European Journal of Teacher Education*, 35(2), 163–178. doi: 10.1080/02619768.2011.643395

- Carmona, C., Buunk, A. P., Peiró, J. M., Rodríguez, I., & Bravo, M. J. (2006). Do social comparison and coping styles play a role in the development of burnout? Cross-sectional and longitudinal findings. *Journal of Occupational and Organizational Psychology*, 79(1), 85–99. doi: 10.1348/096317905X40808
- Carnicer, J. G., & Calderón, C. (2014). Empathy and coping strategies as predictors of well-being in Spanish university students. *Electronic Journal of Research in Educational Psychology*, 12(1), 129–146. doi: 10.14204/ejrep.32.13117
- Chan, D. W. (2003). Hardiness and its role in the stress–burnout relationship among prospective Chinese teachers in Hong Kong. *Teaching and Teacher Education*, 19(4), 381–395. doi:10.1016/S0742-051X(03)00023-4
- Chang, M. L. (2009). An appraisal perspective of teacher burnout: Examining the emotional work of teachers. *Educational Psychology Review*, 21(3), 193–218. doi: 10.1007/s10648-009-9106-y
- Chang, M. L. (2013). Toward a theoretical model to understand teacher emotions and teacher burnout in the context of student misbehavior: Appraisal, regulation and coping. *Motivation and Emotion*, 37(4), 799–817. doi: 10.1007/s11031-012-9335-0
- Chao, R. C. L. (2011). Managing stress and maintaining well-being: Social support, problem-focused coping, and avoidant coping. *Journal of Counseling and Development: JCD*, 89(3), 338. doi: 10.1002/j. 1556-6678.2011.tb00098x
- Chaplain, R. P. (2008). Stress and psychological distress among trainee secondary teachers in England. *Educational Psychology: An International Journal of Experimental Educational Psychology*, 28(2), 195–209. doi: 10.1080/01443410701491858
- Clunies-Ross, P., Little, E., & Kienhuis, M. (2008). Self-reported and actual use of proactive and reactive classroom management strategies and their relationship with teacher stress and student behaviour. *Educational Psychology*, 28(6), 693–710. doi: 10.1080/01443410802206700
- Cobb, S. (1976). Social support as a moderator of life stress. *Psychosomatic Medicine*, 38(5), 300–314. doi: 10.1097/00006842-197609000-00003
- Cohen, L., Manion, L., & Morrison, K. (2011). *Research methods in education* (7<sup>th</sup> ed.). London: Taylor and Francis. ProQuest Ebook Central, Retrieved from <https://ebookcentral.proquest.com/lib/uef-ebooks/detail.action?docID=1144438>. May 4<sup>th</sup>, 2018.
- Cohen, S., Gottlieb, B. H., & Underwood, L. G. (2000). Social relationship and health. In S. Cohen, L. Underwood, & B. Gottlieb, (Eds.), *Social support measurement and intervention: A Guide for health and social scientists* (pp. 3–25). New York: Oxford University Press.
- Cohen, S., & McKay, G. (1985). Social support, stress and the buffering hypothesis: A theoretical analysis. In A. Baum, S. E. Taylor, & J. E. Singer, (Eds.), *Handbook of psychology and health* (pp. 253–267). Hillsdale, New Jersey: Erlbaum. Retrieved from <http://www.psy.cmu.edu/~scohen/buffer84.pdf>. September 4<sup>th</sup>, 2014.
- Cohen, S., & Syme, S. L. (1985). Issues in the study and application of social support. In S. Cohen & S. L. Syme, (Eds.), *Social support and health* (pp. 3–21). San Francisco: Academic Press. Retrieved from <http://www.psy.cmu.edu/~scohen/symechap85.pdf>. August 26<sup>th</sup>, 2014.
- Cooke, R., Bewick, B. M., Barkham, M., Bradley, M., & Audin, K. (2006). Measuring, monitoring and managing the psychological well-being of first year university students. *British Journal of Guidance & Counselling*, 34(4), 505–517. doi: 10.1080/03069880600942624
- Cox, J. W., & Hassard, J. (2007). Ties to the past in organization research: A comparative analysis of retrospective methods. *Organization*, 14(4), 475–497. doi: 10.1177/1350508407078049
- Creswell, J. W. (2013). *Qualitative inquiry & research design. Choosing among five approaches* (3rd ed.). Los Angeles: Sage.
- Creswell, J. W. (2014). *Research design: Qualitative, quantitative, and mixed methods approaches* (4th ed.). Los Angeles: Sage.
- Creswell, J. W., & Plano Clark, V. L. (2017). *Designing and conducting mixed methods research* (3<sup>rd</sup> ed.). Thousand Oaks, CA: Sage.
- Daniels, L. M., Clifton, R. A., Perry, R. P., Mandzuk, D., & Hall, N. C. (2006). Student teachers' competence and career certainty: The effects of career anxiety and perceived control. *Social Psychology of Education*, 9(4), 405–423. doi: 10.1007/s11218-006-9000-0
- Davis, C. G., & Asliturk, E. (2011). Toward a positive psychology of coping with anticipated events. *Canadian Psychology/Psychologie Canadienne*, 52(2), 101. doi: 10.1037/a0020177
- Deci, E. L., & Ryan, R. M. (2000). The "what" and "why" of goal pursuits: Human needs and the self-determination of behavior. *Psychological Inquiry*, 11(4), 227–268. doi: 10.1207/S15327965PI1104\_01
- De Ridder, D., & Kerssens, J. (2003). Owing to the force of circumstances? The impact of situational features and personal characteristics on coping patterns across situations. *Psychology & Health*, 18(2), 217–236. doi: 10.1080/0887044021000044242

- Devos, C., Dupriez, V., & Paquay, L. (2012). Does the social working environment predict beginning teachers' self-efficacy and feelings of depression? *Teaching and Teacher Education*, 28(2), 206–217. doi: 10.1016/j.tate.2011.09.008
- Diener, E. (2006). Guidelines for national indicators of subjective well-being and ill-being. *Applied Research in Quality of Life*, 1(2), 151–157. doi: 10.1007/s11482-006-9007-x
- Diener, E., Oishi, S., & Lucas, R. E. (2003). Personality, culture, and subjective well-being: Emotional and cognitive evaluations of life. *Annual Review of Psychology*, 54(1), 403–425. doi: 10.1146/annurev.psych.54.1.403
- Diener, E., Oishi, S., & Lucas, R. E. (2011). Subjective well-being: The science of happiness and life satisfaction. In C. R. Snyder & S. J. Lopez (Eds.), *Oxford handbook of positive psychology* (2<sup>nd</sup> ed.) (pp. 187–194). New York: Oxford University Press. Retrieved from [https://books.google.fi/books?hl=fi&lr=&id=6IyqCNBD6oIC&oi=fnd&pg=PA187&dq=diener+subjective+well+being&ots=ILKbMJ3frB&sig=I4MjrnIMnHif8c5EPjPfa17wng&redir\\_esc=y#v=onepage&q=diener%20subjective%20well%20being&f=false](https://books.google.fi/books?hl=fi&lr=&id=6IyqCNBD6oIC&oi=fnd&pg=PA187&dq=diener+subjective+well+being&ots=ILKbMJ3frB&sig=I4MjrnIMnHif8c5EPjPfa17wng&redir_esc=y#v=onepage&q=diener%20subjective%20well%20being&f=false). February 13th, 2017.
- Diener, E., & Ryan, K. (2009). Subjective well-being: A general overview. *South African Journal of Psychology*, 39(4), 391–406. doi: 10.1177/008124630903900402
- Diener, E., Sapyta, J. J., & Suh, E. (1998). Subjective well-being is essential to well-being. *Psychological Inquiry*, 9(1), 33–37. doi: 10.1207/s15327965pli0901\_3
- Donaldson, S. I., & Grant-Vallone, E. J. (2002). Understanding self-report bias in organizational behavior research. *Journal of Business and Psychology*, 17(2), 245–260.
- Dorman, J. P. (2003). Relationship between school and classroom environment and teacher burnout: A LISREL analysis. *Social Psychology of Education*, 6(2), 107–127. doi: 10.1023/A:1023296126723
- Elo, A.-L., Leppänen, A., & Jahkola, A. (2003). Validity of a single-item measure of stress symptoms. *Scandinavian Journal of Work, Environment & Health*, 29(6), 444–451.
- Elo, S., & Kyngäs, H. (2008). The qualitative content analysis process. *Journal of Advanced Nursing*, 62(1), 107–115. doi: 10.1111/j.1365-2648.2007.04569.x
- Evelein, F., Korthagen, F., & Brekelmans, M. (2008). Fulfilment of the basic psychological needs of student teachers during their first teaching experiences. *Teaching and Teacher Education*, 24(5), 1137–1148. doi: 10.1016/j.tate.2007.09.001
- Ferguson, P. (2011). Student perceptions of quality feedback in teacher education. *Assessment & Evaluation in Higher Education*, 36(1), 51–62. doi: 10.1080/02602930903197883
- Fernet, C., Guay, F., Senécal, C., & Austin, S. (2012). Predicting intraindividual changes in teacher burnout: The role of perceived school environment and motivational factors. *Teaching and Teacher Education*, 28(4), 514–525. doi: 10.1016/j.tate.2011.11.013
- Finnish advisory board on research integrity. (2012). Responsible conduct of research and procedures for handling allegations of misconduct in Finland. Guidelines of the Finnish Advisory Board on Research Integrity 2012. Retrieved from [http://www.tenk.fi/sites/tenk.fi/files/HTK\\_ohje\\_2012.pdf](http://www.tenk.fi/sites/tenk.fi/files/HTK_ohje_2012.pdf). June 6<sup>th</sup>, 2017.
- Fives, H., Hamman, D., & Olivarez, A. (2007). Does burnout begin with student-teaching? Analyzing efficacy, burnout, and support during the student-teaching semester. *Teaching and Teacher Education*, 23(6), 916–934. doi: 10.1016/j.tate.2006.03.013
- Folkman, S. (1984). Personal control and stress and coping processes: A theoretical analysis. *Journal of Personality and Social Psychology*, 46(4), 839.
- Ford, J. D., & Blaustein, M. E. (2013). Systemic self-regulation: A framework for trauma-informed services in residential juvenile justice programs. *Journal of Family Violence*, 28(7), 665–677. doi: 10.1007/s10896-013-9538-5
- Fortes-Ferreira, L., Peiró, J. M., Gonzáles-Morales, M. G., & Martín, I. (2006). Work-related stress and well-being: The roles of direct action coping and palliative coping. *Scandinavian Journal of Psychology*, 47(4), 293–302. doi: 10.1111/j.1467-9450.2006.00519.x
- Freudenberger, H. J. (1974). Staff burn-out. *Journal of Social Issues*, 30(1), 159–165. doi: 10.1111/j.1540-4560.1974.tb00706.x
- Gan, Y., Yang, M., Zhou, Y., & Zhang, Y. (2007). The two-factor structure of future-oriented coping and its mediating role in student engagement. *Personality and Individual Differences*, 43(4), 851–863. doi: 10.1016/j.paid.2007.02.009
- Gavish, B., & Friedman, I. A. (2010). Novice teachers' experience of teaching: A dynamic aspect of burnout. *Social Psychology of Education*, 13(2), 141–167. doi: 10.1007/s11218-009-9108-0
- Gelo, O., Braakmann, D., & Benetka, G. (2008). Quantitative and qualitative research: Beyond the debate. *Integrative Psychological and Behavioral Science*, 42(3), 266–290. doi: 10.1007/s12124-008-9078-3

- Geving, A. M. (2007). Identifying the types of student and teacher behaviours associated with teacher stress. *Teaching and Teacher Education*, 23(5), 624–640. doi: 10.1016/j.tate.2007.02.006
- Goddard, R., & Goddard, M. (2006). Beginning teacher burnout in Queensland schools: Association with serious intentions to leave. *The Australian Educational Researcher*, 33(2), 61–75.
- Goddard, R., O'Brien, P., & Goddard, M. (2006). Work environment predictors of beginning teacher burnout. *British Educational Research Journal*, 32(6), 857–874. doi: 10.1080/01411920600989511
- Gottlieb, B. H., & Bergen, A. E. (2010). Social support concepts and measures. *Journal of Psychosomatic Research*, 69(5), 511–520. doi: 10.1016/j.psychores.2009.10.001
- Greenglass, E. R. (2005). Proactive coping, resources and burnout: Implications for occupational stress. In A.-S. G. Antonion & C. L. Cooper (Eds.), *Research companion to organizational health psychology* (pp. 503–515). Cheltenham, UK: Edward Elgar Publishing Limited.
- Greenglass, E. R., & Fiksenbaum, L. (2009). Proactive coping, positive affect, and well-being: Testing for mediation using path analysis. *European Psychologist*, 14(1), 29–39. doi: 10.1027/1016-9040.14.1.29
- Gustems-Carnicer, J., & Calderón, C. (2013). Coping strategies and psychological well-being among teacher education students. *European Journal of Psychology of Education*, 28(4), 1127–1140. doi: 10.1007/s10212-012-0158-x
- Hadwin, A. F., Järvelä, S., & Miller, M. (2011). Self-regulated, co-regulated, and socially shared regulation of learning. In B. J. Zimmerman & D. H. Schunk (Eds.), *Handbook of self-regulation of learning and performance* (pp. 65–84). New York: Routledge.
- Hadwin, A., & Oshige, M. (2011). Self-regulation, coregulation, and socially shared regulation: Exploring perspectives of social in self-regulated learning theory. *Teachers College Record*, 113(2), 240–264.
- Hagger, H., Mutton, T., & Burn, K. 2011. Surprising but not shocking: The reality of the first year of teaching. *Cambridge Journal of Education*, 41(4), 387–405. doi: 10.1080/0305764X.2011.624999
- Hakanen, J. H., Bakker, A. B., & Schaufeli, W. B. (2006). Burnout and work engagement among teachers. *Journal of School Psychology*, 43(6), 495–513. doi: 10.1016/j.jsp.2005.11.001
- Hardt, J., & Rutter, M. (2004). Validity of adult retrospective reports of adverse childhood experiences: Review of the evidence. *Journal of Child Psychology and Psychiatry*, 45(2), 260–273. doi: 10.1111/j.1469-7610.2004.00218.x
- Hascher, T., Cocard, Y., & Moser, P. (2004). Forget about theory-practice is all? Student teachers' learning in practicum. *Teacher and Teaching: theory and practice*, 10(6), 623–637. doi: 10.1080/1354060042000304800
- Heikkilä, A., Lonka, K., Nieminen, J., & Niemivirta, M. (2012). Relations between teacher students' approaches to learning, cognitive and attributional strategies, well-being, and study success. *Higher Education*, 64(4), 455–471. doi: 10.1007/s10734-012-9504-9
- Heikonen, L., Pietarinen, J., Pyhältö, K., Toom, A., & Soini, T. (2017). Early career teachers' sense of professional agency in the classroom: Associations with turnover intentions and perceived inadequacy in teacher–student interaction. *Asia-Pacific Journal of Teacher Education*, 45(3), 250–266. doi: 10.1080/1359866X.2016.1169505
- Helgeson, V. S. (2003). Social support and quality of life. *Quality of Life Research*, 12(1), 25–31.
- Helgeson, V. S., & Gottlieb, B. H. (2000). Support groups. In S. Cohen, L. Underwood, & B. Gottlieb (Eds.), *Social support measurement and intervention: A guide for health and social scientists* (pp. 221–245). New York: Oxford University Press.
- Hennink, M. M., Kaiser, B. N., & Marconi, V. C. (2017). Code saturation versus meaning saturation: How many interviews are enough? *Qualitative Health Research*, 27(4), 591–608. doi: 10.1177/1049732316665344
- Hillel Lavian, R. (2012). The impact of organizational climate on burnout among homeroom teachers and special education teachers (full classes/individual pupils) in mainstream schools. *Teachers and Teaching*, 18(2), 233–247. doi: 10.1080/13540602.2012.632272
- Hobson, A. J. (2002). Student teachers' perceptions of school-based mentoring in initial teacher training (ITT). *Mentoring & Tutoring: Partnership in Learning*, 10(1), 5–20. doi: 10.1080/13611260220133117
- Hobson, A. J. (2009). On being bottom of the pecking order: Beginner teachers' perceptions and experiences of support. *Teacher Development: An international journal of teachers' professional development*, 13(4), 299–320. doi: 10.1080/13664530903578256
- Hong, J. Y. (2010). Pre-service and beginning teachers' professional identity and its relation to dropping out of the profession. *Teaching and Teacher Education*, 26(8), 1530–1543. doi: 10.1016/j.tate.2010.06.003
- Hong, J. Y. (2012). Why do some beginning teachers leave the school, and others stay? Understanding teacher resilience through psychological lenses. *Teachers and Teaching*, 18(4), 417–440. doi: 10.1080/13540602.2012.696044
- Hooper, D., Coughlan, J., & Mullen, M. R. (2008). Structural equation modelling: Guidelines for determining model fit. *Electronic Journal of Business Research Methods*, 6(1), 55–60.

- House, J. (1981). *Work stress and social support*. Reading, Massachusetts: Addison-Wesley.
- House, J. S., Umberson, D., & Landis, K. R. (1988). Structures and processes of social support. *Annual Review of Sociology*, 14(1), 293–318. doi: 10.1146/annurev.so.14.080188.001453
- Howard, S., & Johnson, B. (2004). Resilient teachers: Resisting stress and burnout. *Social Psychology of Education*, 7(4), 399–420. doi: 10.1007/s11218-004-0975-0
- Hoy, A. W., & Spero, R. B. (2005). Changes in teacher efficacy during the early years of teaching: A comparison of four measures. *Teaching and Teacher Education*, 21(4), 343–356. doi: 10.1016/j.tate.2005.01.007
- Hsu, S. (2005). Help-seeking behaviour of student teachers. *Educational Research*, 47(3), 307–318. doi: 10.1080/00131880500287716
- Hu, L., & Bentler, P. M. (1999). Cutoff criteria for fit indexes in covariance structure analysis: Conventional criteria versus new alternatives. *Structural Equation Modeling*, 6(1), 1–55. doi: 10.1080/10705519909540118
- Hultell, D., Melin, B., & Gustavsson, J. P. (2013). Getting personal with teacher burnout: A longitudinal study on the development of burnout using a person-based approach. *Teaching and Teacher Education* 32, 75–86. doi: 10.1016/j.tate.2013.01.007
- Huppert, F. A. (2009). Psychological well-being: Evidence regarding its causes and consequences. *Applied Psychology: Health and well-being*, 1(2), 137–164. doi:10.1111/j.1758-0854.2009.01008.x
- Ingvarson, L., Beavis, A., & Kleinhenz, E. (2004). Teacher education courses in Victoria: Perceptions of their effectiveness and factors affecting their impact. Retrieved from [http://research.acer.edu.au/cgi/viewcontent.cgi?article=1003&context=teacher\\_education](http://research.acer.edu.au/cgi/viewcontent.cgi?article=1003&context=teacher_education). January 7<sup>th</sup>, 2019.
- Jacobs, S. R., & Dodd, D. (2003). Student burnout as a function of personality, social support, and workload. *Journal of College Student Development*, 44(3), 291–303. doi: 10.1353/csd.2003.0028
- Johnson, B., Down, B., Le Cornu, R., Peters, J., Sullivan, A., Pearce, J., & Hunter, J. (2014). Promoting early career teacher resilience: A framework for understanding and acting. *Teachers and Teaching*, 20(5), 530–546. doi: 10.1080/13540602.2014.937957
- Johnson, R. B., & Onwuegbuzie, A. J. (2004). Mixed methods research: A research paradigm whose time has come. *Educational Researcher*, 33(7), 14–26. doi: 10.3102/0013189X033007014
- Johnson, R. B., Onwuegbuzie, A. J., & Turner, L. A. (2007). Toward a definition of mixed methods research. *Journal of Mixed Methods Research*, 1(2), 112–133. doi: 10.1177/1558868906298224
- Jou, Y. H., & Fukada, H. (2002). Stress, health, and reciprocity and sufficiency of social support: The case of university students in Japan. *The Journal of Social Psychology*, 142(3), 353–370. doi: 10.1080/00224540209603904
- Järvelä, S., Volet, S., & Järvenoja, H. (2010). Research on motivation in collaborative learning: Moving beyond the cognitive-situative divide and combining individual social processes. *Educational Psychologist*, 45(1), 15–27. doi: 10.1080/00461520903433539
- Kaldi, S. (2009). Student teachers' perceptions of self-competence in and emotions/stress about teaching in initial teacher education. *Educational Studies*, 35(3), 349–360. doi: 10.1080/03055690802648259
- Kashdan, T. B., Biswas-Diener, R., & King, L. A. (2008). Reconsidering happiness: The costs of distinguishing between hedonics and eudaimonia. *The Journal of Positive Psychology*, 3(4), 219–233. doi: 10.1080/17439760802303044
- Kemper, E. A., Stringfield, S., & Teddlie, C. (2003). Mixed methods sampling strategies in social science research. In A. Tashakkori & C. Teddlie (Eds.), *Handbook of mixed methods in social and behavioral research* (pp. 273–296). Thousand Oaks, CA: Sage Publications.
- Kern, M. L., Waters, L. E., Adler A., & White, M. A. (2015). A multidimensional approach to measuring well-being in students: Application of the PERMA framework. *The Journal of Positive Psychology*, 10(3), 262–271. doi: 10.1080/17439760.2014.936962
- Keyes, C. L., Shmotkin, D., & Ryff, C. D. (2002). Optimizing well-being: The empirical encounter of two traditions. *Journal of Personality and Social Psychology*, 82(6), 1007. doi: 10.1037/0022-3514.82.6.1007
- Klassen, R. M., & Durksen, T. L. (2014). Weekly self-efficacy and work stress during the teaching practicum: A mixed methods study. *Learning and Instruction*, 33, 158–169. doi:10.1016/j.learninstruc.2014.05.003
- Klassen, R. M., Perry, N. E., & Frenzel, A. C. (2012). Teachers' relatedness with students: An underemphasized component of teachers' basic psychological needs. *Journal of Educational Psychology*, 104(1), 150–165. doi: 10.1037/a0026253
- Kline, R. B. (2015). *Principles and practice of structural equation modeling*. Guilford publications.
- Knight, C., Balatti, J., Haase, M., & L. Henderson, L. (2010). Preservice teacher stressors and their reactions to those stressors: Resilient responses. Paper presented in ATEA Conference, Townsville, July 4–7.
- Kokkinos, C. M. (2007). Job stressors, personality and burnout in primary school teachers. *British Journal of Educational Psychology*, 77(1), 229–243. doi: 10.1348/000709905x90344

- Krefting, L. (1991). Rigor in qualitative research: The assessment of trustworthiness. *American Journal of Occupational Therapy*, 45(3), 214–222.
- Kuula, A. (2013). *Tutkimuseetiikka. Aineistojen hankinta, käyttö ja säilytys* (3rd ed.). [In Finnish]. Tampere: Vastapaino.
- Kvale, S. (2007). *Doing interviews*. Los Angeles, California: SAGE.
- Kyriacou, C. (2001). Teacher stress: Directions for future research. *Educational Review*, 53(1), 27–35. doi: 10.1080/00131910120033628
- Lam, B.-h., & Yan, H.-f. (2011). Beginning teachers' job-satisfaction: The impact of school-based factors. *Teacher Development*, 15(3), 333–348. doi: 10.1080/13664530.2011.608516
- Lambert, R. G., McCarthy, C., O'Donnell, M., & Wang, C. (2009). Measuring elementary teacher stress and coping in the classroom: Validity evidence for the classroom appraisal of resources and demands. *Psychology in the Schools*, 46(10), 973–988. doi:10.1022/pits.20438
- Lazarus, R. S., & Folkman, S. (1984). *Stress, appraisal, and coping*. New York: Springer Publishing Company.
- Le Cornu, R. (2009). Building resilience in pre-service teachers. *Teaching and Teacher Education*, 25(5), 717–723. doi: 10.1016/j.tate.2008.11.016
- Leech, N. L., & Onwuegbuzie, A. J. (2009). A typology of mixed methods research designs. *Quality & Quantity*, 43(2), 265–275. doi: 10.1007/s11135-007-9105-3
- Leiter, M. (1993). Burnout as a developmental process: Consideration of models. In W. B. Schaufeli, C. Maslach, & T. Marek (Eds.), *Professional burnout* (pp. 237–250). Philadelphia, PA: Taylor & Francis.
- Leiter, M. P., & Maslach, C. (2016). Latent burnout profiles: A new approach to understanding the burnout experience. *Burnout Research*, 3(4), 89–100. doi: 10.1016/j.burn.2016.09.001
- Leskinen, E. (2005). Pitkittäisaineistojen analyysistä latenttien muuttujien malleilla. *Psykologia*, 40(5–6), 476–488. [In Finnish].
- Lincoln, Y. S., & Guba, E. G. (2000). The only generalization is: There is no generalization. In R. Gomm, M. Hammersley, & P. Foster (Eds.), *Case study method: Key issues, key texts* (pp. 27–44). London: Sage.
- Lindqvist, H., Weurlander, M., Wernerson, A., & Thornberg, R. (2017). Resolving feelings of professional inadequacy: Student teachers' coping with distressful situations. *Teaching and Teacher Education*, 64, 270–279. doi: 10.1016/j.tate.2017.02.019
- Linley, P. A., Maltby, J., Wood, A. M., Osborne, G., & Hurling, R. (2009). Measuring happiness: The higher order factor structure of subjective and psychological well-being measures. *Personality and Individual Differences*, 47(8), 878–884. doi: 10.1016/j.paid.2009.07.010
- Lipponen, L., & Kumpulainen, K. (2011). Acting as accountable authors: Creating interactional spaces for agency work in teacher education. *Teaching and Teacher education*, 27(5), 812–819. doi: 10.1016/j.tate.2011.01.001
- MacFarlane, A., & O'Reilly-de Brún, M. (2011). Using a theory-driven conceptual framework in qualitative health research. *Qualitative Health Research*, 22(5), 607–618. doi: 10.1177/1049732311431898
- Malinen, O. P., Väisänen, P., & Savolainen, H. (2012). Teacher education in Finland: A review of a national effort for preparing teachers for the future. *Curriculum Journal*, 23(4), 567–584. doi: 10.1080/09585176.2012.731011
- Malterud, K. (2001). Qualitative research: Standards, challenges, and guidelines. *The Lancet*, 358(9280), 483–488. doi: 10.1016/S0140-6736(01)05627-6
- Maslach, C. (2003). Job burnout: New directions in research and intervention. *Current Directions in Psychological Science*, 12(5), 189–192. doi: 10.1111/1467-8721.01258
- Maslach, C., & Goldberg, J. (1998). Prevention of burnout: New perspectives. *Applied & Preventive Psychology*, 7(1), 63–74. doi: 10.1016/S0962-1849(98)80022-X
- Maslach, C., & Jackson, S. E. (1981). The measurement of experienced burnout. *Journal of Occupational Behaviour*, 2, 99–113.
- Maslach, C., & Leiter, M. P. (2008). Early predictors of job burnout and engagement. *Journal of Applied Psychology*, 93(3), 498–512. doi: 10.1037/0021-9010.93.3.498
- Maslach, C., Schaufeli, W. B., & Leiter, M. P. (2001). Job burnout. *Annual Review of Psychology*, 52, 397–422. doi: 10.1146/annurev.psych.52.1.397
- McCallum, F., & Price, D. (2010). Well teachers, well students. *The Journal of Student Wellbeing*, 4(1), 19–34. doi: 10.21913/JSW.v.4i1.599
- Miles, M. B., & Huberman, A. M. (1994). *Qualitative data analysis: An expanded sourcebook* (2nd ed.). Thousand Oaks, California: Sage.
- Misra, R., & McKean, M. (2000). College students' academic stress and its relation to their anxiety, time management, and leisure satisfaction. *American Journal of Health Studies*, 16(1), 41–51.

- Moneta, G. B. (2011). Need for achievement, burnout, and intention to leave: Testing an occupational model in educational settings. *Personality and Individual Differences*, 50(2), 274–278. doi: 10.1016/j.paid.2010.10.002
- Munthén, L., & Munthén, B. O. (1998–2017). *Mplus users guide* (8<sup>th</sup> ed.). Los Angeles, CA: Munthén & Munthén.
- Murray-Harvey, R., Slee, P. T., Lawson, M. J., Silins, H., Banfield, G., & Russell, A. (2000). Under stress: The concerns and strategies of teaching education students. *European Journal of Teacher Education*, 23(1), 19–35. doi: 10.1080/713667267
- Newman, R. S. (2002). How self-regulated learners cope with academic difficulty: The role of adaptive help seeking. *Theory Into Practice*, 41(2), 132–138. doi: 10.1207/s15430421tip4102\_10
- Newman, R. S. (2008). Adaptive and nonadaptive help seeking with peer harassment: An integrative perspective of coping and self-regulation. *Educational Psychologist*, 43(1), 1–15. doi: 10.1080/00461520701756206
- Niemi, H., & Jakku-Sihvonen, R. (2006a). In the front of the Bologna process. Thirty years of research-based teacher education in Finland. *Education Science*, 66–79.
- Niemi, H., & Jakku-Sihvonen, R. (2006b). Research-based teacher education. In R. Jakku-Sihvonen & H. Niemi (Eds.), *Research-based teacher education in Finland. Reflections by Finnish teacher educators* (pp. 31–50). Research in Educational Sciences 25.
- Niemi, H. & Jakku-Sihvonen, R. (2011). Teacher education in Finland. In M. V. Zuljan & J. Vogrinc (Eds.), *European dimensions of teacher education – Similarities and differences* (pp. 33–51). Retrieved from ukviz.solazaravnatelj.si/ISBN/978-961-253-058-7/files/978-961-253-058-7.pdf. October 9<sup>th</sup>, 2015.
- Nunnally, J. C., & Bernstein, I. H. (1994). *Psychometric theory* (3<sup>rd</sup> ed.). New York: McGraw-Hill.
- Onwuegbuzie, A. J., & Leech, N. L. (2010). Generalization practices in qualitative research: A mixed methods case study. *Quality & Quantity*, 44(5), 881–892. doi: 10.1007/s11135-009-9241-z
- Opettajankoulutus 2020. Opetusministeriö. Opetusministeriön työryhmämuistioita ja selvityksiä 2007:44 [In Finnish]. Retrieved from [www.minedu.fi/export/sites/default/OPM/Julkaisut/2007/liitteet/tr44.pdf?lang=fi](http://www.minedu.fi/export/sites/default/OPM/Julkaisut/2007/liitteet/tr44.pdf?lang=fi). January 9<sup>th</sup>, 2017.
- Opetushallitus. (2017). Opettajat ja rehtorit Suomessa 2016. Retrieved from [https://www.oph.fi/download/185380\\_opettajat\\_ja\\_rehtorit\\_Suomessa\\_esite.pdf](https://www.oph.fi/download/185380_opettajat_ja_rehtorit_Suomessa_esite.pdf). June 2<sup>nd</sup>, 2019.
- Paquette, K. R., & Rieg, S. A. (2016). Stressors and coping strategies through the lens of early childhood/special education pre-service teachers. *Teaching and Teacher Education*, 57, 51–58. doi: 10.1016/j.tate.2016.03.009
- Pashiardis, G. (2000). School climate in elementary and secondary schools: Views of Cypriot principals and teachers. *International Journal of Educational Management*, 14(5), 224–237. doi: 10.1108/09513540010373162
- Patton, M. Q. (2002). *Qualitative research & evaluation methods* (3<sup>rd</sup> ed.). Thousand Oaks, CA: Sage Publications.
- Peeters, M. A. G., & Rutte, C. G. (2005). Time management behavior as a moderator for the job demand-control interaction. *Journal of Occupational Health Psychology*, 10(1), 64–75. doi: 10.1037/1076-8998.10.1.64
- Pierceall, E. A., & Keim, M. C. (2007). Stress and coping strategies among community college students. *Community College Journal of Research and Practice*, 31(9), 703–712. doi: 10.1080/10668920600866579
- Pietarinen, J., Pyhältö, K., Soini, T., & Salmela-Aro, K. (2013a). Reducing teacher burnout: A socio-contextual approach. *Teaching and Teacher Education*, 35, 62–72. doi: 10.1016/j.tate.2013.05/003
- Pietarinen, J., Pyhältö, K., Soini, T., & Salmela-Aro, K. (2013b). Validity and reliability of the Socio-contextual Teacher Burnout Inventory (STBI). *Psychology*, 4(1), 73–82. doi: 10.4236/psych.2013.41010
- Pillay, H. K., Goddard, R., & Wilss, L. A. (2005). Well-being, burnout and competence: Implications for teachers. *Australian Journal of Teacher Education*, 30(2), 22–33. doi: 10.14221/ajte.2005v30n2.3
- Pogodzinski, B. (2013). Collegial support and novice teachers’ perceptions of working conditions. *Journal of Educational Change*, 15(4), 467–489. doi: 10.1007/s10833-013-9221-x
- Price, D., & McCallum, F. (2015). Ecological influences on teachers’ well-being and “fitness”. *Asia-Pacific Journal of Teacher Education*, 43(3), 195–209. doi: 10.1080/1359866X.2014.932329
- Pyhältö, K. M. (2018). Function of supervisory and researcher community support in PhD and post- PhD trajectories. In E. Bizer, M. Fourie-Malherbe, L. Frick, & K. Pyhältö (Eds.), *Spaces, journeys and new horizons for postgraduate supervision* (pp. 203–216). SUN PreSS Series: Research into the Higher Education. AFRICAN SUN MeDIA
- Pyhältö, K., Pietarinen, J., & Salmela-Aro, K. (2011). Teacher–working–environment fit as a framework for burnout experienced by Finnish teachers. *Teaching and Teacher Education*, 27(7), 1101–1110. doi: 10.1016/j.tate.2011.05.006



- Raffe, D., Bundell, L., & Bibby, J. (2005). Ethics and tactics: Issues arising from an educational survey. In R. G. Burgess (Ed.), *The ethics of educational research* (pp.11–27). New York: The Falmer Press.
- Rajuan, M., Beijaard, D., & Verloop, N. (2008a). Student teachers' perceptions of their mentors as internal triggers for learning. *Teaching Education, 19*(4), 279–292. doi: 10.1080/10476210802339951
- Rajuan, M., Beijaard, D., & Verloop, N. (2008b). What do student teachers learn? Perceptions of learning in mentoring relationships. *The New Educator, 4*(2), 133–151. doi: 10.1080/15476880802014314
- Randi, J., Corno, L., & Johnson, E. (2011). Transition from college classroom to teaching career: Self-regulation in prospective teachers. *New Directions for Teaching and Learning, 126*, 89–98. doi: 10.2202/1949-6605.1829
- Reavey, P. (2012). The return to experience. Psychology and the visual. In P. Reavey (Ed.), *Visual methods in psychology: Using and interpreting images in qualitative research* (pp. 1–14). New York, NY: Routledge.
- Reichl, C., Wach, F.-S., Spinath, F. M., Brünken, R., & Karbach, J. (2014). Burnout risk among first-year teacher students: The roles of personality and motivation. *Journal of Vocational Behavior, 85*(1), 85–92. doi: 10.1016/j.jvb.2014.05.002
- Renk, K., & Smith, T. (2007). Predictors of academic-related stress in college students: An examination of coping, social support, parenting, and anxiety. *Naspa Journal, 44*(3), 405–431. doi: 10.2202/1949-6605.1829
- Rieg, S. A., Paquette, K. R., & Chen, Y. (2007). Coping with stress: An investigation of novice teachers' stressors in the elementary classroom. *Education, 128*(2), 211–226.
- Roffey, S. (2012). Pupil wellbeing—teacher wellbeing: Two sides of the same coin? *Educational and Child Psychology, 29*(4), 8.
- Ryan, A. M., Pintrich, P. R., & Midgley, C. (2001). Avoiding seeking help in the classroom: Who and why? *Educational Psychology Review, 13*(2), 93–114. doi: 10.1023/A:1009013420053
- Ryan, R. M., & Deci, E. L. (2000). Self-determination theory and the facilitation of intrinsic motivation, social development, and well-being. *American Psychologist, 55*(1), 68. doi: 10.1037//0003-066X.55.1.68
- Ryan, R. M., & Deci, E. L. (2011). A self-determination theory perspective on social, institutional, cultural, and economic supports for autonomy and their importance for well-being. In V. Chirkov, R. M. Ryan, & K. M. Sheldon (Eds.), *Human autonomy in cross-cultural context: Perspectives on the psychology of agency, freedom, and well-being* (pp. 45–64). Springer Netherlands. doi: 10.1007/978-90-481-9667-8
- Ryff, C. D. (1995). Psychological well-being in adult life. *Current Directions in Psychological Science, 4*(4), 99–104. doi: 10.1111/1467-8721.ep10772395
- Ryff, C. D., & Keyes, C. L. M. (1995). The structure of psychological well-being revisited. *Journal of Personality and Social Psychology, 69*(4), 719. doi: 10.1037/0022-3514.69.4.719
- Saariaho, E., Anttila, H., Toom, A., Soini, T., Pietarinen, J., & Pyhältö, K. (2018). Student teachers' emotional landscapes in self- and co-regulated learning. *Teachers and Teaching: theory and practice, 24*(5), 538–558. doi: 10.1080/13540602.2018.1430565
- Saariaho, E., Pyhältö, K., Toom, A., Pietarinen, J., & Soini, T. (2015). Student teachers' self- and co-regulation of learning during teacher education. *Learning: Research and Practice, 2*(1), 44–63. doi: 10.1080/23735082.2015.1081395
- Salami, S. O. (2010). Emotional intelligence, self-efficacy, psychological well-being and students' attitudes: Implications for quality education. *European Journal of Educational Studies, 2*(3), 247–257.
- Salmela-Aro, K. (2009). Opiskelu-uupumismittari SBI-9 yliopisto- ja ammattikorkeakouluopiskelijoille [In Finnish]. *Ylioppilaiden terveydenhoitosäätiön tutkimuksia 46*. Helsinki: Kehitys Oy.
- Salmela-Aro, K., & Kunttu, K. (2010). Study burnout and engagement in higher education. *Unterrichtswissenschaft, 38*, 318–333.
- Salmela-Aro, K., & Read, S. (2017). Study engagement and burnout profiles among Finnish higher education students. *Burnout Research, 7*, 21–28. doi: 10.1016/j.burn.2017.11.001
- Salmela-Aro, K., Savolainen, H., & Holopainen, L. (2009). Depressive symptoms and school burnout during adolescence: Evidence from two cross-lagged longitudinal studies. *Journal of Youth and Adolescence, 38*(10), 1316–1327. doi: 10.1007/s10964-008-9334-3
- Samman, E. (2007). Psychological and subjective well-being: A proposal for internationally comparable indicators. *Oxford Development Studies, 35*(4), 459–486. doi: 10.1080.13600810701939
- Saunders, B., Sim, J., Kingstone, T., Baker, S., Waterfield, J., Bartlam, B., Burroughs, H., & Jinks, C. (2018). Saturation in qualitative research: exploring its conceptualization and operationalization. *Quality & Quantity, 52*(4), 1893–1907. doi: 10.1007/s11135-017-0574-8
- Schaufeli, W. B., Martínez, I. M., Pinto, A. M., Salanova, M., & Bakker, A. B. (2002). Burnout and engagement in university students. *Journal of Cross-Cultural Psychology, 33*(5), 464–481. doi: 10.1177/0022022102033005003

- Schaufeli, W. B., & Salanova, M. (2007). Efficacy or inefficacy, that's the question: Burnout and work engagement, and their relationship with efficacy beliefs. *Anxiety, Stress, and Coping*, 20(2), 177–196. doi: 10.1080/10615800701217878
- Schilling, J. (2006). On the pragmatics of qualitative assessment: Designing the process for content analysis. *European Journal of Psychological Assessment*, 22(1), 28. doi: 10.1027/1015-5759.22.1.28
- Schlichte, J., Yssel, N., & Merbler, J. (2005). Pathways to burnout: Case studies in teacher isolation and alienation. *Preventing School Failure: Alternative Education for Children and Youth*, 50(1), 35–40. doi: 10.3200/PSFL.50.1.35.35–40
- Schonfeld, I. S. (2001). Stress in 1st-year women teachers: The context of social support and coping. *Genetic, Social, and General Psychology Monographs*, 127(2), 133.
- Schreiber, J. B., Nora, A., Stage, F. K., Barlow, E. A., & King, J. (2006). Reporting structural equation modeling and confirmatory factor analysis results: A review. *The Journal of Educational Research*, 99(6), 323–338. doi: 10.3200/JOER.99.6.323-338
- Schreier, M. 2012. *Qualitative content analysis in practice*. Thousand Oaks, California: SAGE. Retrieved from [https://books.google.fi/books?id=FYkQAgAAQBAJ&pg=PA25&lpg=PA25&dq=theory+driven+content+analysis+qualitative+research+article&source=bl&ots=wH1bj\\_fDPg&sig=xJkk5tXBWR61mmxkO\\_6f0EepWt8&hl=fi&sa=χ&ei=wqyOVML3A4f4ygPWvYFw&ved=0CCcQ6AEwATgU#v=onepage&q=theory%20driven%20content%20analysis%20qualitative%20research%20article&f=false](https://books.google.fi/books?id=FYkQAgAAQBAJ&pg=PA25&lpg=PA25&dq=theory+driven+content+analysis+qualitative+research+article&source=bl&ots=wH1bj_fDPg&sig=xJkk5tXBWR61mmxkO_6f0EepWt8&hl=fi&sa=χ&ei=wqyOVML3A4f4ygPWvYFw&ved=0CCcQ6AEwATgU#v=onepage&q=theory%20driven%20content%20analysis%20qualitative%20research%20article&f=false). January 5th, 2015.
- Schwarzer, R., & Knoll, N. (2003). Positive coping: Mastering demands and searching for meaning. In S. J. Lopez & C. R. Snyder (Eds.), *Positive psychological assessment: A handbook of models and measures* (pp. 393–409). Washington, DC: American Psychological Association. Retrieved from [http://userpage.fu-berlin.de/~health/materials/s\\_knoll\\_coping.pdf](http://userpage.fu-berlin.de/~health/materials/s_knoll_coping.pdf). April 14<sup>th</sup>, 2017.
- Schwarzer, R., & Knoll, N. (2007). Functional roles of social support within the stress and coping process: A theoretical and empirical overview. *International Journal of Psychology*, 42(4), 243–252. doi: 10.1080/00207590701396641
- Schwarzer, R., & Taubert, S. (2002). Tenacious goal pursuits and striving toward personal growth: Proactive coping. In E. Frydenberg (Ed.), *Beyond coping: Meeting goals, visions and challenges* (pp. 19–35). London: Oxford University Press. Retrieved from [http://userpage.fu-berlin.de/~health/materials/s\\_taubert\\_proactive.pdf](http://userpage.fu-berlin.de/~health/materials/s_taubert_proactive.pdf), January 7<sup>th</sup>, 2019
- Selig, J. P., & Little, T. D. (2012). Autoregressive and cross-lagged panel analysis for longitudinal data. In B. Laursen, T. D. Little, & N. A. Card (Eds.), *Handbook of developmental research methods* (pp. 265–278). Guilford Press.
- Selvitys opettajankoulutuksesta 14.11.2011. Opetus- ja kulttuuriministeriö [In Finnish]. Retrieved from [www.minedu.fi/exports/sites/default/OPM/Koulutus/ammattikorkeakoulutus/opiskelu\\_ja\\_tutkinnot/Selvitys\\_opettajankoulutuksesta\\_14112011.pdf](http://www.minedu.fi/exports/sites/default/OPM/Koulutus/ammattikorkeakoulutus/opiskelu_ja_tutkinnot/Selvitys_opettajankoulutuksesta_14112011.pdf). December 20<sup>th</sup>, 2016.
- Sharplin, E., O'Neill, M., & Chapman, A. (2011). Coping strategies for adaptation to new teacher appointments: Intervention for retention. *Teaching and Teacher Education*, 27(1), 136–146. doi: 10.1016/j.tate.2010.07.010
- Shen, Y. E. (2009). Relationships between self-efficacy, social support and stress coping strategies in Chinese primary and secondary school teachers. *Stress and Health*, 25(2), 129–138. doi: 10.1002/smi.1229
- Shumaker, S. A., & Brownell, A. (1984). Toward a theory of social support: Closing conceptual gaps. *Journal of Social Issues*, 40(4), 11–36. doi: 10.1111/j.1540-4560.1984.tb01105.x
- Skaalvik, E. M., & Skaalvik, S. (2010). Teacher self-efficacy and teacher burnout: A study of relations. *Teaching and Teacher Education*, 26(4), 1059–1069. doi: 10.1016/j.tate.2009.11.001
- Skaalvik, E. M., & Skaalvik, S. (2015). Job satisfaction, stress and coping strategies in the teaching profession – What do teachers say? *International Education Studies*, 8(3), 181–192. doi: 10.5539/ies.v8n3p181
- Skaalvik, E. M., & Skaalvik, S. (2017). Motivated for teaching? Associations with school goal structure, teacher self-efficacy, job satisfaction and emotional exhaustion. *Teaching and Teacher Education*, 67, 152–160. doi: 10.1016/j.tate.2017.06.006
- Smith, K., & Lev-Ari, L. (2005). The place of the practicum in pre-service teacher education: The voice of the students. *Asia-Pacific Journal of Teacher Education*, 33(3), 289–302. doi: 10.1080/13598660500286333
- Sohl, S. J., & Moyer, A. (2009). Refining the conceptualization of a future-oriented self-regulatory behavior: Proactive coping. *Personality and Individual Differences*, 47(2), 139–144. doi: 10.1016/j.paid.2009.02.013
- Soini, T., Pietarinen, J., Toom, A., & Pyhältö, K. (2015). What contributes to first-year student teachers' sense of professional agency on the classroom? *Teachers and Teaching: theory and practice*, 21(6), 641–659. doi: 10.1080/13540602.2015.1044326

- Soini, T., Pyhältö, K., & Pietarinen, J. (2010). Pedagogical well-being: Reflecting learning and well-being in teachers' work. *Teacher and Teaching: theory and practice*, 16(6), 735–751. doi: 10.1080/13540602.2010.517690
- Stallman, H. M. (2010). Psychological distress in university students: A comparison with general population data. *Australian Psychologist*, 45(4), 249–257. doi: 10.1080/00050067.2010.482019
- Stockard, J., & Lehman, M. B. (2004). Influences on the satisfaction and retention of 1st-year teachers: The importance of effective school management. *Educational Administration Quarterly*, 40(5), 742–771. doi: 10.1177/0013161X04268844
- Straud, C., McNaughton-Cassill, M., & Fuhrman, R. (2015). The role of the Five Factor Model of Personality with proactive coping and preventive coping among college students. *Personality and Individual Differences*, 83, 60–64. doi: 10.1016/j.paid.2015.03.055
- Säntti, J. (1999). *Opiskelukyvyn jäljillä* [In Finnish]. Opiskelijajärjestöjen tutkimussäätiö Otus rs 15/1999. Helsinki.
- Tang, S. Y. F. (2003). Challenge and support: The dynamics of student teachers' professional learning in the field experience. *Teaching and Teacher Education*, 19, 483–498. doi: 10.1016/S0742-051X(03)00047-7
- Taris, T. W., Le Blanc, P. M., Schaufeli, W. B., & Schreurs, P. J. G. (2005). Are there causal relationships between the dimensions of the Maslach Burnout Inventory? A review and two longitudinal tests. *Work & Stress*, 19(3), 238–255. doi: 10.1080/02678370500270453
- Tashakkori, A. & Teddlie, C. (2016). *SAGE handbook of mixed methods in social & behavioral research* (2<sup>nd</sup> ed.). Thousand Oaks, CA: SAGE Publications Ltd. Retrieved from <http://methods.sagepub.com/book/sage-handbook-of-mixed-methods-social-behavioral-research-2e>. March 27<sup>th</sup>, 2016.
- Tavakol, M., & Dennick, R. (2011). Making sense of Cronbach's alpha. *International Journal of Medical Education*, 2, 53–55. doi: 10.5116/ijme.4dbf.8dfd
- Teddlie, C., & Tashakkori, A. (2003). Major issues and controversies in the use of mixed methods in the social and behavioral sciences. In A. Tashakkori & C. Teddlie (Eds.), *Handbook of mixed methods in social and behavioral research* (pp. 3–50). Thousand Oaks, CA: Sage Publications.
- Thoits, P. A. (1995). Stress, coping, and social support processes: Where are we? What next? *Journal of Health and Social Behavior*, 53–79. doi: 10.2307/2626957
- Thoits, P. A. (2011). Mechanisms linking social ties and support to physical and mental health. *Journal of Health and Social Behavior*, 52(2), 145–161. doi: 10.1177/0022146510395592
- Tilastokeskus. (2018). Yliopistokoulutus 2017. Retrieved from [http://www.stat.fi/til/yop/2017/yop\\_2017\\_2018-05-08\\_fi.pdf](http://www.stat.fi/til/yop/2017/yop_2017_2018-05-08_fi.pdf). June 2<sup>nd</sup>, 2019.
- Timoššuk, I., & Ugaste, A. (2010). Student teachers' professional identity. *Teaching and Teacher Education*, 26(8), 1563–1570. doi: 10.1016/j.tate.2010.06.008
- Timoššuk, I., & Ugaste, A. (2012). The role of emotions in student teachers' professional identity. *European Journal of Teacher Education*, 35(4), 421–433. doi: 10.1080/02619768.2012.662637
- Toom, A., Kynäslähti, H., Krokfors, L., Jyrhämä, R., Byman, R., Stenberg, K., Maaranen, K., & Kansanen, P. (2010). Experiences of a research-based approach to teacher education: Suggestions for future policies. *European Journal of Education*, 45(2), 331–344. doi: 10.1111/j.1465-3435.2010.01432.x
- Tsouloupas, C. N., Carson, R. L., Matthews, R., Grawitch, M. J., & Barber, L. K. (2010). Exploring the association between teachers' perceived student misbehaviour and emotional exhaustion: The importance of teacher efficacy beliefs and emotion regulation. *Educational Psychology*, 30(2), 173–189. doi: 10.1080/01443410903494460
- Tuominen-Soini, H., & Salmela-Aro, K. (2014). Schoolwork engagement and burnout among Finnish high school students and young adults: Profiles, progressions, and educational outcomes. *Developmental Psychology*, 50(3), 649–662. doi: 10.1037/a0033898
- Tynjälä, P., & Heikkinen, H. L. T. (2011). Beginning teachers' transition from pre-service education to working life. Theoretical perspectives and best practices. *Z Erziehungswiss*, 14, 11–33. doi: 10.1007/s11618-011-0175-6
- Unterbrink, T., Hack, A., Pfeifer, R., Buhl-Grießhaber, V., Müller, U., Wesche, H., Frommhold, M., Scheuch, K., Wirsching, M., & Bauer, J. (2007). Burnout and effort-reward-imbalance in a sample of 949 German teachers. *International Archives of Occupational and Environmental Health*, 80(5), 433–441. doi: 10.1007/s00420-007-0169-0
- Valtioneuvoston asetus yliopistojen tutkinnoista (794/2004) [In Finnish]. Retrieved from <http://www15.uta.fi/opiskelu2/o-opas/laak/tutkintoasetus.pdf>. January 9<sup>th</sup>, 2017.
- Verešová, M., & Malá, D. (2012). Stress, proactive coping and self-efficacy of teachers. *Procedia-Social and Behavioral Sciences*, 55, 294–300. doi: 10.1016/j.sbspro.2012.09.506

- Watt, H. M. G., & Richardson, P. W. (2008). Motivations, perceptions, and aspirations concerning teaching as a career for different types of beginning teachers. *Learning and Instruction, 18*(5), 408–428. doi: 10.1016/j.tate.2011.01.001
- Westbury, I., Hansén, S. E., Kansanen, P., & Björkqvist, O. (2005). Teacher education for research-based practice in expanded roles: Finland's experience. *Scandinavian Journal of Educational Research, 49*(5), 475–485. doi: 10.1080/00313830500267937
- Wolff, J. K., Schmiedek, F., Brose, A., & Lindenberger, U. (2013). Physical and emotional well-being and the balance of needed and received emotional support: Age differences in a daily diary study. *Social Science & Medicine, 91*, 67–75. doi: 10.1016/j.socscimed.2013.04.033
- Yager, Z. (2009). Developing wellbeing in first year pre-service teachers: Reflections on a personal approach to professional education. *The Journal of Student Wellbeing, 3*(1), 52–72. doi: 10.21913/JSW.v2i1.419
- Yardley, L. (2008). Demonstrating validity in qualitative psychology. In J. A. Smith (Ed.), *Qualitative psychology: A practical guide to research methods*, (2<sup>nd</sup> ed.). (pp. 235–251). London: Sage.
- Zhang, Y., Gan, Y., & Cham, H. (2007). Perfectionism, academic burnout and engagement among Chinese college students: A structural equation modeling analysis. *Personality and Individual Differences, 43*(6), 1529–1540. doi: 10.1016/j.paid.2007.04.010
- Zimmerman, B. (2002). Becoming a self-regulated learner: An overview. *Theory Into Practice, 41*(2), 64–70. doi: 10.1207/s15430421tip4102\_2

# APPENDICES

## **APPENDIX 1. CONTEXTUALLY MODIFIED VERSION OF THE TEACHERS' PROFESSIONAL LANDSCAPE INVENTORY (TPLI) INSTRUMENT (TRANSLATED FROM FINNISH)**

### **Intro for the interview**

Today we are going to go through your experiences during teacher education and through regarding teacher work. The interview data will be treated confidentially and only the members of the research group will handle it. Also, the identity of the participants will be protected and they can't be identified from the reported results. The interview is divided into three parts: first I will ask you some background information, then we will discuss about your experiences during teacher education and in the end I would like you to reflect on your future work as a teacher.

### **I I as a teacher and my teaching experience**

1. What kind of teacher qualification you get from your education? Are you studying to become a primary school teacher or a subject teacher?
2. What made you want to become a teacher?
3. How much do you currently have experience on teacher's work? Do you have other teaching experience in addition to normative teaching practice? If so, what kind and how much?

### **II Conceptions of your own agency in teacher education**

4. You will graduate soon. What are your thoughts and how do you feel regarding your studies?

Here interviewees were asked to make a visualisation of their teacher studies on a piece of paper as they saw it; they drew and visualised their journeys as timelines, winding roads on maps. These visualisations were used to support the sharing and discussing of the experiences. Then the participants were asked to identify and mark on their visualisations the key positive, promoting events and the key negative, hindering events that made a difference in their studies. After that, the students were interviewed based on their visualisations. They were asked to describe their experiences one event at the a time, and were requested to clarify and elaborate on their descriptions: when and where the key event in question occurred, why they thought it had occurred, and what happened after the event, as well as whether others had contributed to it. We encouraged interviewees to recall what, for them, had been the most significant (e.g., most challenging or inspiring) situations and periods during the studies that may have influenced their learning and development as teachers.

5. Describe and visualise your learning path in teacher education to this paper. The image may be a timeline or other suitable way to describe the study path. Mark the significant events of your study path to the visualisation. The situation may be:

- positive/inspiring or negative/frustrating
- a single encounter with a person or in a longer course/study period, during which you will learn something essential for future work

These are support questions for visualisation based interview; each event was recalled by addressing these questions.

- What happened? Can you tell more about the event? Who was there?
  - What made the event particularly significant?
  - What changed (thought or activity)? What did you think at first, how did your thoughts change after the event? What made you change your thought or actions? How did you feel?
  - What essentials did you learn about teachers' work and being a teacher?
  - How typical/atypical is the study situation you described? If the situation was atypical, what is the typical learning situation in teacher education?
  - In addition to the above-mentioned situations, do you have in mind any longer episodes that influenced your thoughts of being a teacher or alternatively, situations that in a surprising and quick way impacted your conceptions of being a teacher?
6. Have your thoughts changed during the teacher education? If, how? Would you describe briefly how your thoughts have changed during your study path? What did you think in the beginning of your studies, and what do you think now?
7. How would you describe teacher education from student's perspective? How is the studying here? Describe a typical day of studying and what happens during the day.
8. How do you think that a teacher educator sees the learning environment? What kind of is everyday work for teacher educators here?
9. How would you describe a typical pedagogical situation in teacher education? What is happening and who in present? What the teacher educator is doing, what the students are doing?
10. What kind of strengths do you think the teacher education has supported?
11. Is there any kind of challenge/question/issue that wonders you regarding your future work as a teacher? If so, where do you get support to this at the moment?
12. Do you think that teacher education should be further developed? If yes, how? What should be done to reach that aim you just described?

### **III Perceptions about teachers' professional agency in primary school**

13. How is the everyday life in schools in teachers' perspective? Describe a typical work day and what happens during the day.
14. How is the everyday life in schools in pupils' perspective? Describe a typical school day and what happens during the day.
15. You are almost a qualified teacher: What do you consider your core tasks as a teacher? Why? How do you act to achieve your goals and to fulfil your core task?
16. Describe a typical lesson in your future class. What is happening? What the teacher is doing, what the students are doing?

17. How do you see the importance of the professional community for your future work?
18. How would you like a) your pupils, b) the parents, c) the headmaster and other teachers do describe your working/work with you as a teacher?
19. Do you think that primary schools should be developed further? If yes, to what direction? How would we get into a situation you described?
20. Is there still something you would like to tell me or clarify?

## APPENDIX 2. THE SCALES AND ITEMS FOR EXPLORING THE RELATIONS BETWEEN STUDENT TEACHERS' PROACTIVE STRATEGIES AND EXPERIENCED STUDY-RELATED BURNOUT (TRANSLATED FROM FINNISH)

| Scales*   | Factor Determinacy |
|---|--------------------|
| 1) Proactive strategy (SECOND ORDER-FACTOR FACTORIAL STRUCTURE)   | .89                |
| Self-regulation (SELF-REG):   | .93                |
| Stra11: <i>I know how to regulate my own pace of work in my studies.</i>  |                    |
| Stra12: <i>I know how to delimit my studying.</i>   |                    |
| Stra13: <i>I know when I should slow my pace in studying.</i>   |                    |
| Stra14: <i>You can learn to regulate how you cope in your studies.</i>  |                    |
| Co-regulation (CO-REG):   | .90                |
| Stra21: <i>I know how to support my fellow students who are burdened by studies.</i>  |                    |
| Stra22: <i>When I face exhausting situations in my studies, I ask my fellow students for support.</i>   |                    |
| Stra23: <i>I am increasingly capable of recognising situations where I have succeeded as a student.</i>   |                    |
| 2) Study-related burnout (THREE-FACTOR FACTORIAL STRUCTURE)   |                    |
| Exhaustion in studies (EXH)   | .93                |
| Exh11: <i>Stress means a situation in which a person feels tense, restless, nervous or anxious or is unable to sleep at night because his/her mind is troubled all the time. Do you feel this kind of stress related to your studies?</i> |                    |
| Exh12: <i>I feel quite burnt out.</i>   |                    |
| Exh13: <i>Concerns related to my studies occupy my mind in my spare time.</i>   |                    |
| Inadequacy in studying (INAD)   | .95                |
| Inad21: <i>I often feel that I am failing in my studies.</i>  |                    |
| Inad22: <i>I often have feelings of insufficiency in my studies.</i>  |                    |
| Inad23: <i>I am repeatedly questioning whether I have worked enough for my studies.</i>   |                    |
| Cynicism towards studies (CYN)  | .90                |
| Cyn31: <i>Studying does not inspire me.</i>   |                    |
| Cyn32: <i>It is difficult for me to find a clear meaning for my studies.</i>  |                    |

\* The item scale: *completely disagree* 1 2 3 4 5 6 *completely agree* 7. In single stress item (EXH11) the scale is from one to ten: *Not at all* 1 2 3 4 5 6 7 8 9 *Very much* 10.



## APPENDIX 3. THE SCALES AND ITEMS FOR EXPLORING THE RELATIONS BETWEEN STUDENT TEACHERS' PROACTIVE STRATEGIES, LEARNING ENVIRONMENT IN TEACHER EDUCATION AND EXPERIENCED STUDY-RELATED BURNOUT (TRANSLATED FROM FINNISH)

---

### Scales\*

---

#### 1) Self-regulative proactive strategy (SELF):

*I know how to regulate my own pace of work in my studies.*  
*I know how to delimit my studying.*  
*I know when I should slow my pace in studying.*  
*You can learn to regulate how you cope in your studies.*

#### 2) Co-regulative proactive strategy (CO):

*I know how to support my fellow students who are burdened by studies.*  
*When I face exhausting situations in my studies, I ask my fellow students for support.*  
*I am increasingly capable of recognising situations where I have succeeded as a student.*

#### 3) Learning environment in teacher education (ENV)

*I receive encouragement and support from teacher educators. (support)*  
*In teacher education problems are dealt constructively. (support)*  
*I can discuss openly about problems concerning studying with teacher educators. (support)*  
*I am treated respectfully. (equality)*  
*I am treated equally. (equality)*  
*There is a good atmosphere for studying in teacher education. (climate)*  
*I can tell openly about my failures to my peer teacher students. (climate)*  
*Teacher educators are interested about my opinions. (recognition)*  
*I feel that teacher educators appreciate my efforts in studying. (recognition)*

#### 4) Study-related burnout (BURNOUT)

*Stress means a situation in which a person feels tense, restless, nervous or anxious or is unable to sleep at night because his/her mind is troubled all the time. Do you feel this kind of stress related to your studies? (exhaustion)*  
*I feel quite burnt out. (exhaustion)*  
*Concerns related to my studies occupy my mind in my spare time. (exhaustion)*  
*I often feel that I am failing in my studies. (inadequacy)*  
*I often have feelings of insufficiency in my studies. (inadequacy)*  
*I am repeatedly questioning whether I have worked enough for my studies. (inadequacy)*  
*Studying does not inspire me. (cynicism)*  
*It is difficult for me to find a clear meaning for my studies. (cynicism)*

---

\* The item scale: *completely disagree* 1 2 3 4 5 6 *completely agree* 7. In single stress item (EXH) the scale is from one to ten: *Not at all* 1 2 3 4 5 6 7 8 9 *Very much* 10.

## **APPENDIX 4. GENERAL DATA PROTECTION REGULATION**

Legislation on the processing of personal data has been changed between the collection and analysis of the research data and the completion of dissertation study when the EU's General Data Protection Regulation (EU 2016/679) and the Data Protection Act (1050/2018) have entered into force. Data protection impact assessment has been carried out on the processing of personal data in this research.

# ORIGINAL ARTICLES

## ARTICLE I

This is an Accepted Manuscript of an article published by Taylor & Francis in *Research Papers in Education*, available online: <http://www.tandfonline.com/10.1080/02671522.2015.1129643>

Väisänen, S., Pietarinen, J., Pyhältö, K., Toom, A., & Soini, T. (2016). Social support as a contributor to student teachers' experienced well-being. *Research Papers in Education*, 32(1), 41–55. doi: 10.1080/02671522.2015.1129643

## ARTICLE II

This is an Accepted Manuscript of an article published by Taylor & Francis in *European Journal of Teacher Education*, available online: <http://www.tandfonline.com/10.1080/02619768.2018.1448777>

Väisänen, S., Pietarinen, J., Pyhältö, K., Toom, A., & Soini, T. (2018). Student teachers' proactive strategies for avoiding study-related burnout during teacher education. *European Journal of Teacher Education*, 41(3), 301–317 doi: 10.1080/02619768.2018.1448777

## ARTICLE III

This is a published article by Canadian Center of Science and Education in *Journal of Education and Learning*, available online: <http://www.ccsenet.org/journal/index.php/jel/article/view/70740>

Väisänen, S., Pietarinen, J., Pyhältö, K., Toom, A., & Soini, T. (2018). Student teachers' proactive strategies and experienced learning environment for reducing study-related burnout. *Journal of Education and Learning*, 7(1), 208–222. doi:10.5539/jel.v7n1p208



## SANNA VÄISÄNEN

---

*The aim of the study was to investigate the construction and regulation of the student teachers' study well-being during teacher education. The dissertation study contributes to the literature on student teachers' study well-being by showing how study well-being is constructed in relation to learning environment and social support resources experienced in teacher education. Furthermore, the study shows how student teachers proactively regulate their study well-being.*



UNIVERSITY OF  
EASTERN FINLAND

*uef.fi*

**PUBLICATIONS OF  
THE UNIVERSITY OF EASTERN FINLAND**  
*Dissertations in Education, Humanities, and Theology*

ISBN 978-952-61-3125-2  
ISSN 1798-5625